

1

Copyright (C) Nokia Corporation. All rights reserved.  
 THIS DRAWING IS PROTECTED BY COPYRIGHT AS AN UNPUBLISHED WORK.  
 UNAUTHORIZED REPRODUCTION OF THIS DRAWING IS NOT PERMITTED.  
 THIS DRAWING CONTAINS PROPRIETARY AND CONFIDENTIAL INFORMATION.  
 This document is property of Nokia Corporation

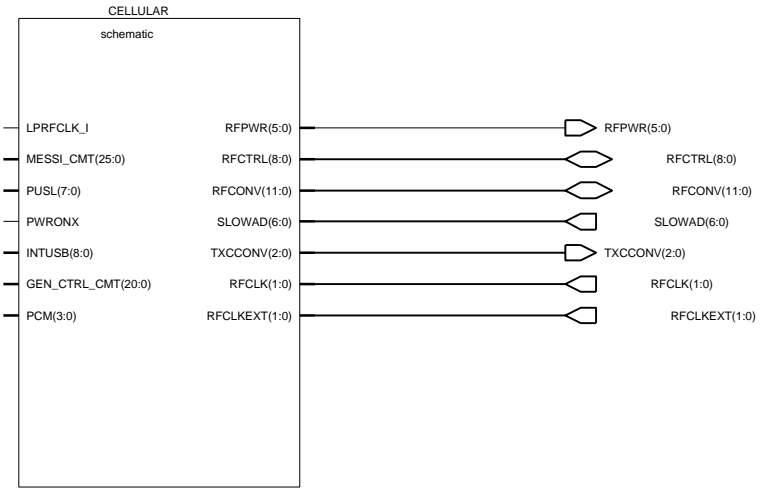

Name	Top sheet	Appr	dd-mmm-yy
Assoc	Cosmo B1.0	Des.	HUIKARI 09-Mar-99
		Dr.	DREWS 08-Feb-06
File	\$COSMO/pro/engine/1fw_30		Sheet 01 of 34 1(01)
Proj	SOHO	Draw.	Print Yes V. 0.0 Edit 211



Copyright (C) Nokia Corporation. All rights reserved.  
 THIS DRAWING IS PROTECTED BY COPYRIGHT AS AN UNPUBLISHED WORK.  
 UNAUTHORIZED REPRODUCTION OF THIS DRAWING IS NOT PERMITTED.  
 THIS DRAWING CONTAINS PROPRIETARY AND CONFIDENTIAL INFORMATION.  
 This document is property of Nokia Corporation



Name	BB Top Level	Appr	dd-mmm-yy
Assoc	Yoda S0.2w	Des.	KAYRA 14-Jan-03
File	\$COSMO/pro/engine/1fw_20/SYS	Dr.	ZIEGER 11-Oct-05
Proj	GRAPE	Sheet	02 of 34 1 (01)
		Print	Yes v. 0 Edit 48

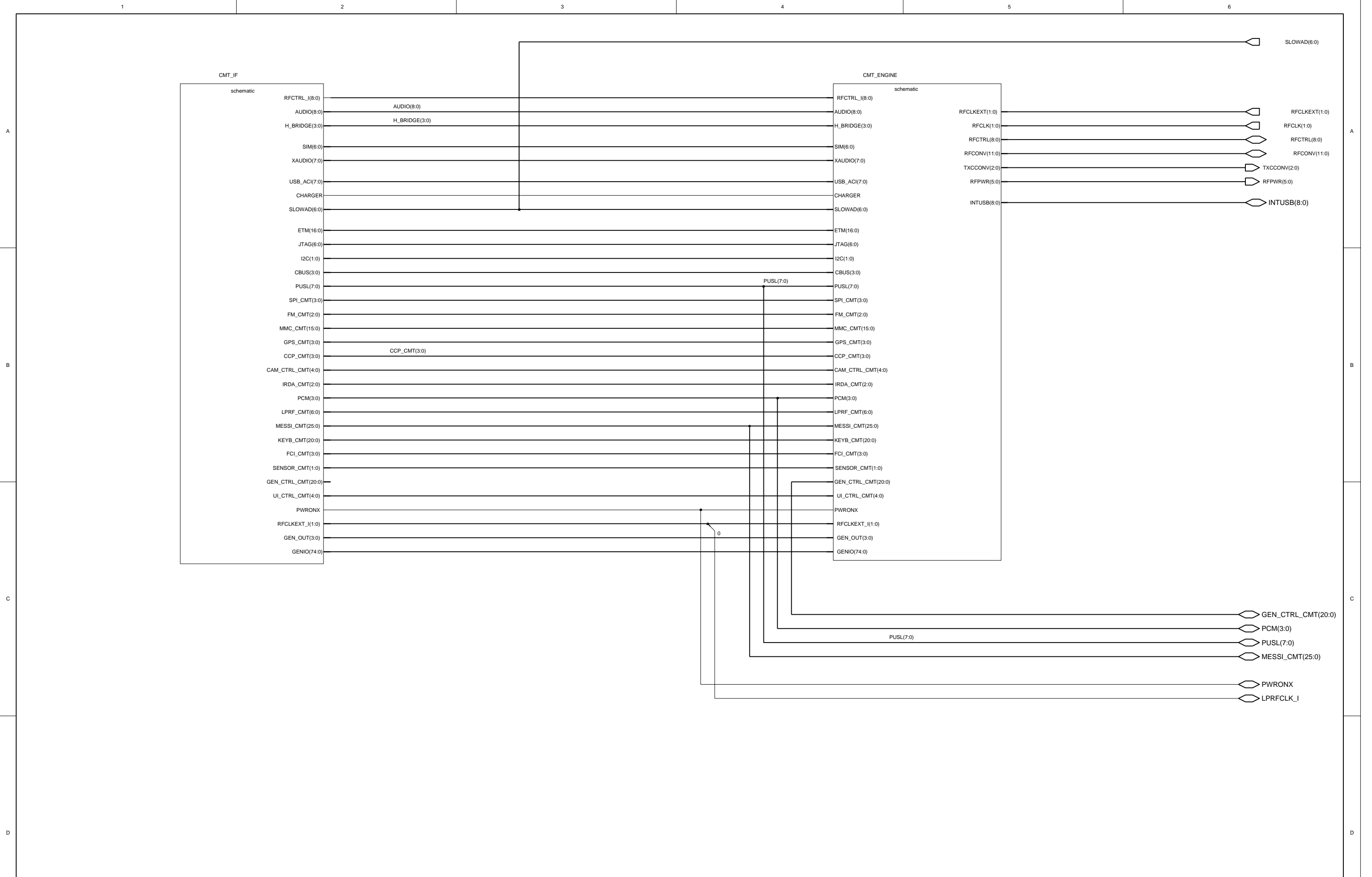

Copyright (C) Nokia Corporation. All rights reserved.  
 THIS DRAWING IS PROTECTED BY COPYRIGHT AS AN UNPUBLISHED WORK.  
 UNAUTHORIZED REPRODUCTION OF THIS DRAWING IS NOT PERMITTED.  
 THIS DRAWING CONTAINS PROPRIETARY AND CONFIDENTIAL INFORMATION.  
 This document is property of Nokia Corporation



Name	BB Top Level	Appr	dd-mmm-yy
Assoc	Yoda S0.5	Des.	KAYRA 14-Jan-03
		Dr.	ZIEGER 11-Oct-05
File	\$COSMO/pro/engine/1fw_20/SYS/cellular		Sheet 03 of 34 1(01)
Proj	CBB5X	Draw.	Print Yes v. 0 Edit 43

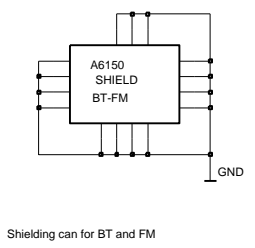
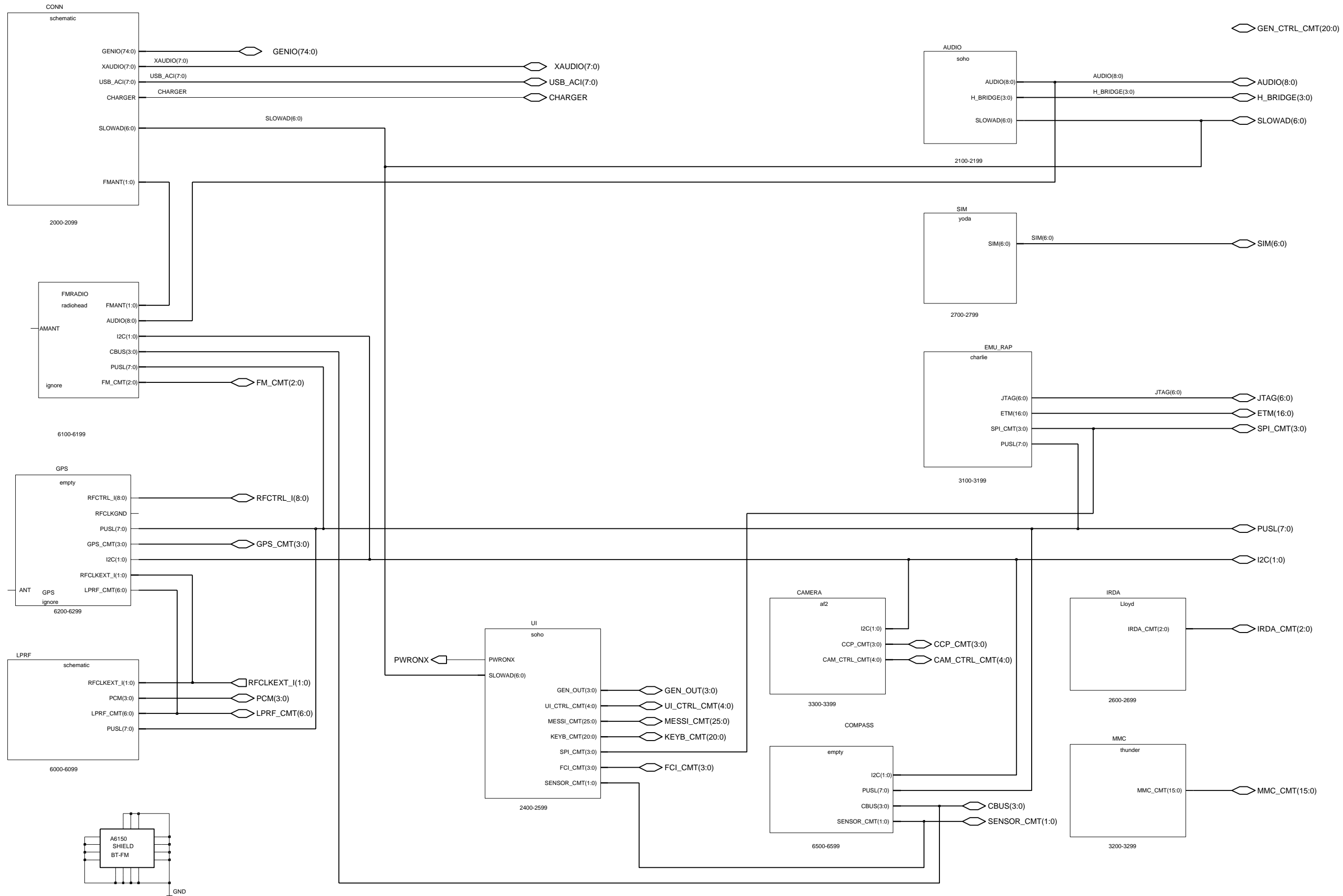

Copyright (C) Nokia Corporation. All rights reserved.  
 THIS DRAWING IS PROTECTED BY COPYRIGHT AS AN UNPUBLISHED WORK.  
 UNAUTHORIZED REPRODUCTION OF THIS DRAWING IS NOT PERMITTED.  
 THIS DRAWING CONTAINS PROPRIETARY AND CONFIDENTIAL INFORMATION.  
 This document is property of Nokia Corporation



Name	CMT_IF Top Level	Appr	dd-mmm-yy
Assoc	Cosmo B1.0	Des.	ArKa 27-May-03
File	\$(COSMO)/pro/engine/1fw_20/SYS/cellular/cmt_if	Dr.	DREWS 17-Nov-05
Proj	GRAPE	Sheet	04 of 34 3 (01)
		Print	Yes V. 0.0 Edit 124

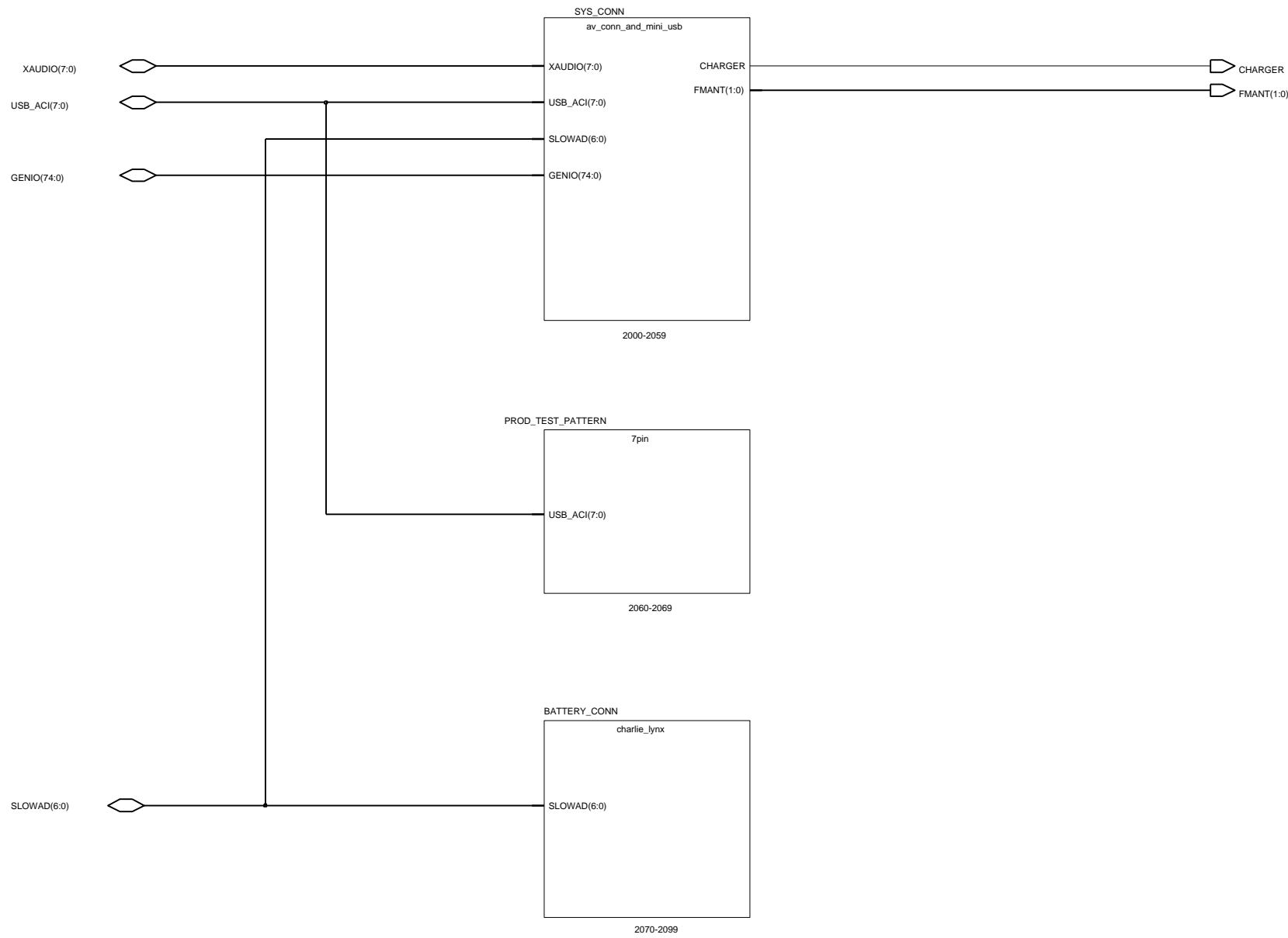

Copyright (C) Nokia Corporation. All rights reserved.  
 THIS DRAWING IS PROTECTED BY COPYRIGHT AS AN UNPUBLISHED WORK.  
 UNAUTHORIZED REPRODUCTION OF THIS DRAWING IS NOT PERMITTED.  
 THIS DRAWING CONTAINS PROPRIETARY AND CONFIDENTIAL INFORMATION.  
 This document is property of Nokia Corporation



Name	System and battery connector	Appr	10-Aug-00
Assoc	Cosmo B1.0	Des.	KAYRA 18-Jan-02
		Dr.	ZIEGER 11-Oct-05
File	\$COSMO/pro/engine/1fw_20/SYS/cellular/cmt_if/conn		Sheet 05 of 34 1 (01)
Proj	GRAPE	Drw.	Print Yes V. 0,1 Edit 40

1

2

3

4

5

6

A

A

B

B

C

C

D

D

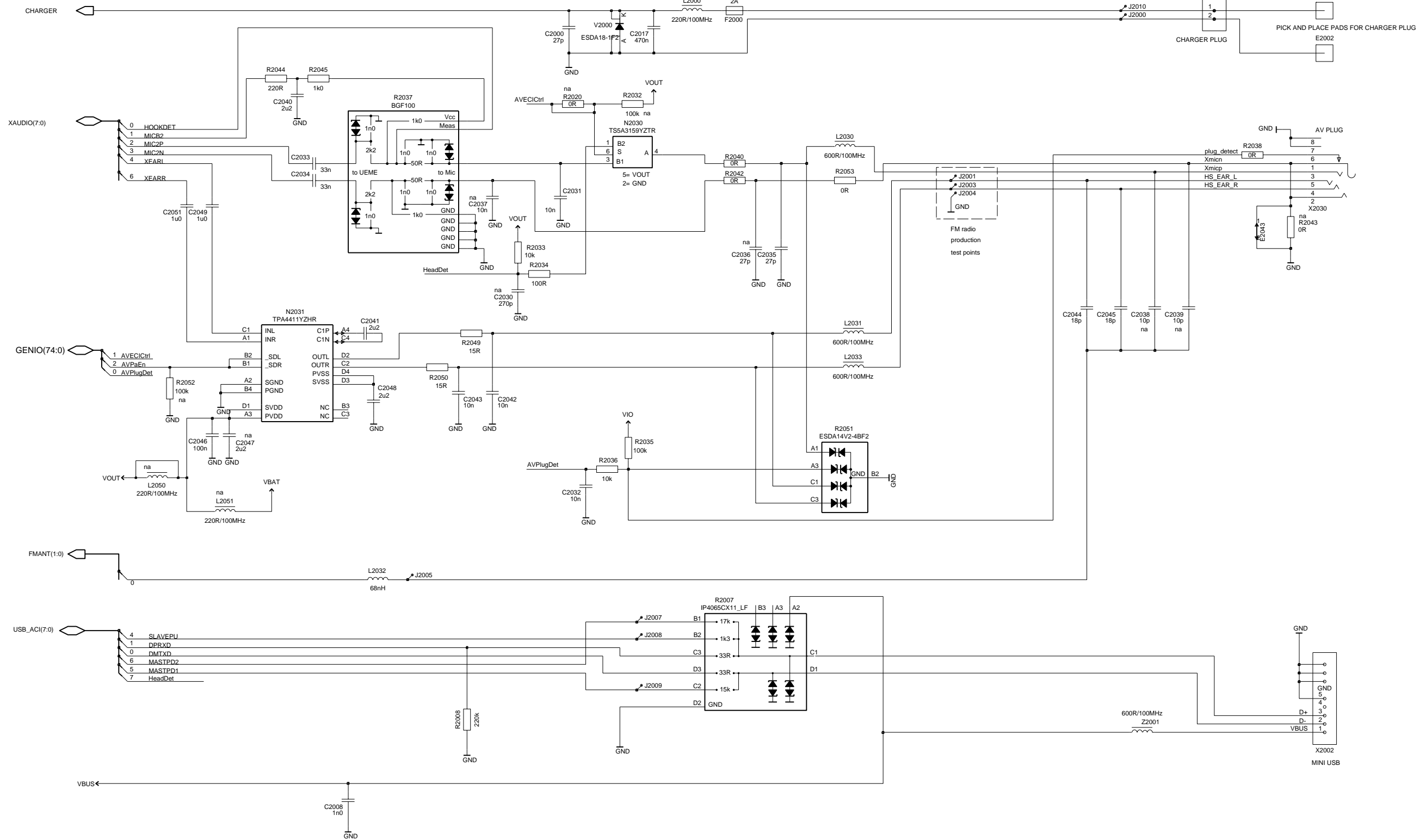

Copyright (C) Nokia Corporation. All rights reserved.  
 THIS DRAWING IS PROTECTED BY COPYRIGHT AS AN UNPUBLISHED WORK.  
 UNAUTHORIZED REPRODUCTION OF THIS DRAWING IS NOT PERMITTED.  
 THIS DRAWING CONTAINS PROPRIETARY AND CONFIDENTIAL INFORMATION.  
 This document is property of Nokia Corporation



Name	System connector	Appr	dd-mmm-yy
Assoc	Cosmo B2.0	Des.	11-Jun-03
File	\$/COSMO/pro/engine/1fw_30/SYS/cellular/cmt_if/sys_conn	Dr.	ZIEGER 06-Feb-06
Proj	GRAPE	Sheet	06 of 34 1 (01)
		Print	Yes V. 0.0 Edit 158

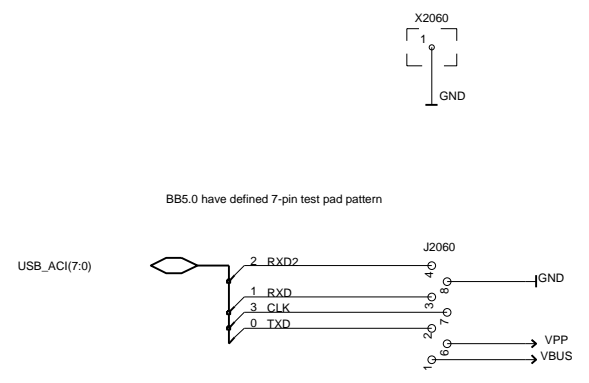

Copyright (C) Nokia Corporation. All rights reserved.  
 THIS DRAWING IS PROTECTED BY COPYRIGHT AS AN UNPUBLISHED WORK.  
 UNAUTHORIZED REPRODUCTION OF THIS DRAWING IS NOT PERMITTED.  
 THIS DRAWING CONTAINS PROPRIETARY AND CONFIDENTIAL INFORMATION.  
 This document is property of Nokia Corporation



Name	Production test pad	Appr	10-Aug-00
Assoc	Yoda S0.5	Des.	KAYRA 18-Jan-02
		Dr.	ZIEGER 11-Oct-05
File	\$COSMO/pro/engine/1fw_20/SYS/cellular/cmt_if/prod_test_pattern		Sheet 07 of 34 1 (01)
Proj	GRAPE	Drw.	Print Yes V. 0,1 Edit 23

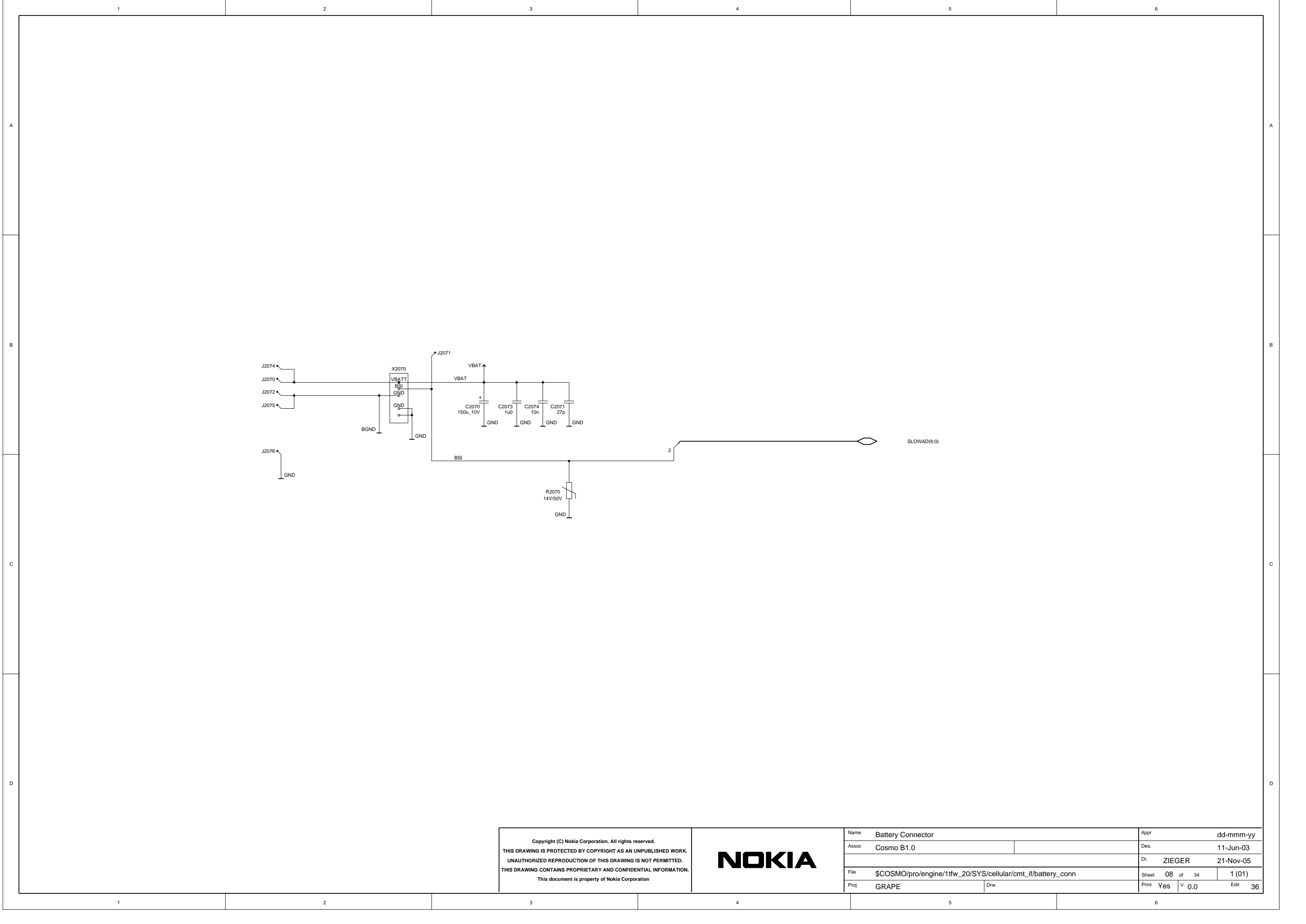

Copyright (C) Nokia Corporation. All rights reserved.  
 THIS DRAWING IS PROTECTED BY COPYRIGHT AS AN UNPUBLISHED WORK.  
 UNAUTHORIZED REPRODUCTION OF THIS DRAWING IS NOT PERMITTED.  
 THIS DRAWING CONTAINS PROPRIETARY AND CONFIDENTIAL INFORMATION.  
 This document is property of Nokia Corporation



Name	Battery Connector	Appr	dd-mmm-yy
Assoc	Cosmo B1.0	Des.	11-Jun-03
File	Proj	Dr.	1 (01)
\$COSMO/pro/engine/1fw_20/SYS/cellular/cmt_if/battery_conn	GRAPE	ZIEGER	21-Nov-05
Print	Yes	V. 0.0	Edit 36

1 2 3 4 5 6

A

A

B

B

C

C

D

D

1 2 3 4 5 6



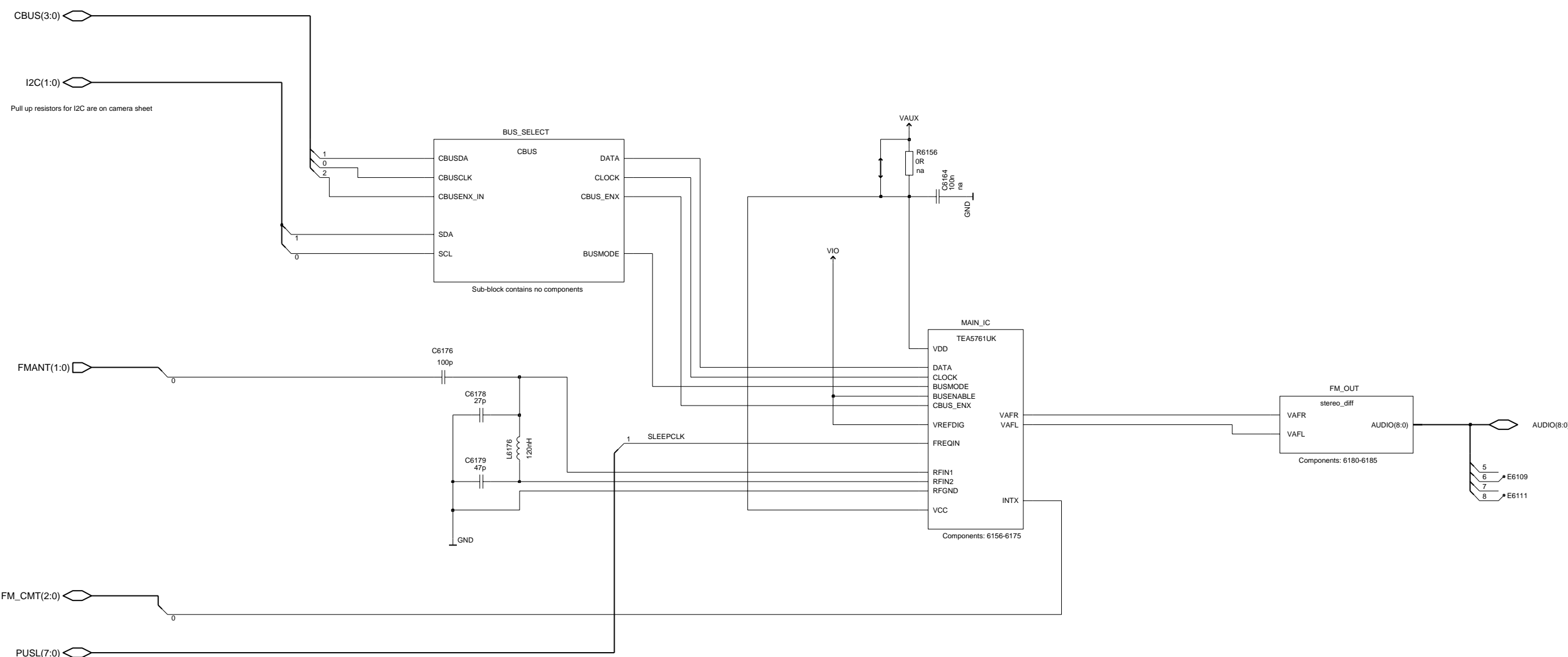

Note: For Layout information, see FM Radio Application Note: Document No. DHJ00379

Interface Designation	BB Release	G_MAP sheet Recommended connection(s)	Signal	Function
G_FMRADIO(5)	BB4.0	GENIO(24)	INTX	Falling Edge Interrupt
	BB4.5	GENIO(8) or GENIO(9) or GENIO(10) or GENIO(11)		
FmRadio_2V7_ANA		VANA	VCC/VDD	Main 2.7Vdc Supply
FmRadio_1V8_Dig		VIO	VREFDIG	1.8Vdc IO Supply



Copyright (C) Nokia Corporation. All rights reserved.  
 THIS DRAWING IS PROTECTED BY COPYRIGHT AS AN UNPUBLISHED WORK.  
 UNAUTHORIZED REPRODUCTION OF THIS DRAWING IS NOT PERMITTED.  
 THIS DRAWING CONTAINS PROPRIETARY AND CONFIDENTIAL INFORMATION.  
 This document is property of Nokia Corporation



Name	Top Level for Radiohead ICs	Appr	dd-mmm-yy
Assoc		Des.	P.J.Waterman 21-May-03
		Dr.	ZIEGER 21-Nov-05
File	\$/COSMO/pro/engine/1fw_20/SYS/cellular/cmt_if/fmradio	Sheet	09 of 34 1 (01)
Proj	Radiohead	Print	Yes V. 0.0 Edit 104

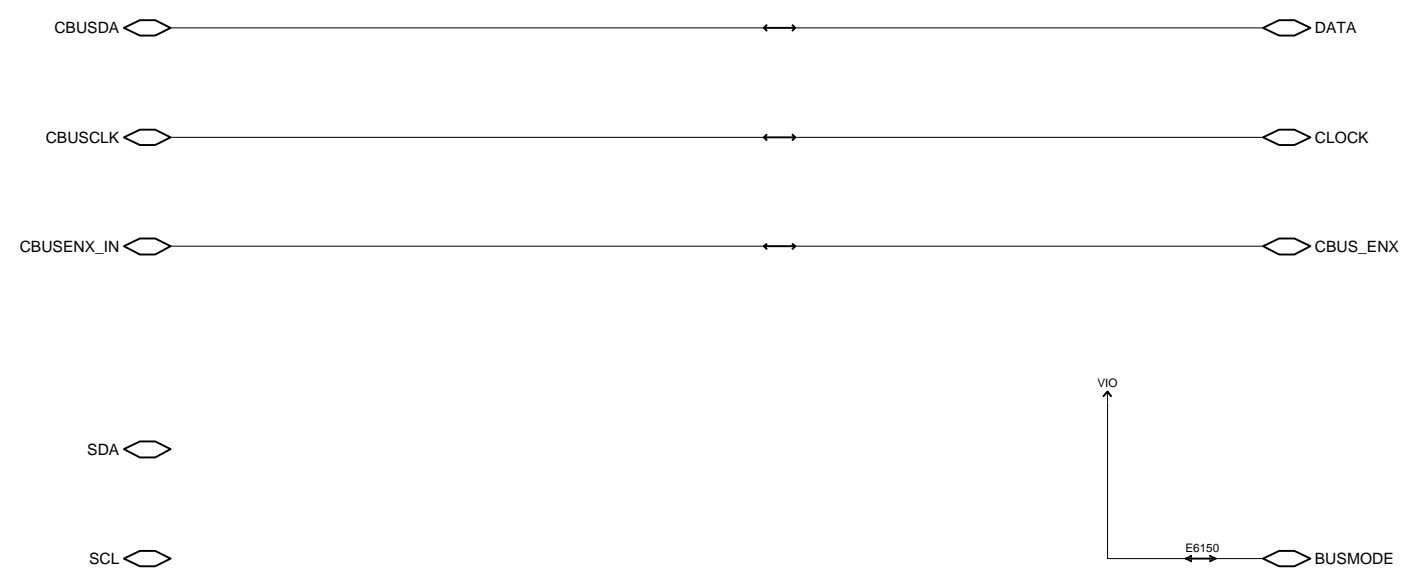

Copyright (C) Nokia Corporation. All rights reserved.  
 THIS DRAWING IS PROTECTED BY COPYRIGHT AS AN UNPUBLISHED WORK.  
 UNAUTHORIZED REPRODUCTION OF THIS DRAWING IS NOT PERMITTED.  
 THIS DRAWING CONTAINS PROPRIETARY AND CONFIDENTIAL INFORMATION.  
 This document is property of Nokia Corporation



Name	CBUS	Appr	dd-mmm-yy
Assoc		Des.	P.J.Waterman 21-May-03
File	\$COSMO/pro/engine/1fw_30/SYS/cellular/cmt_if/fmradio/bus_select		Dr. DREWS 13-Jan-06
Proj	Radiohead	Sheet	10 of 34 0 (01)
Print	Yes	V.	0.0 Edit 19

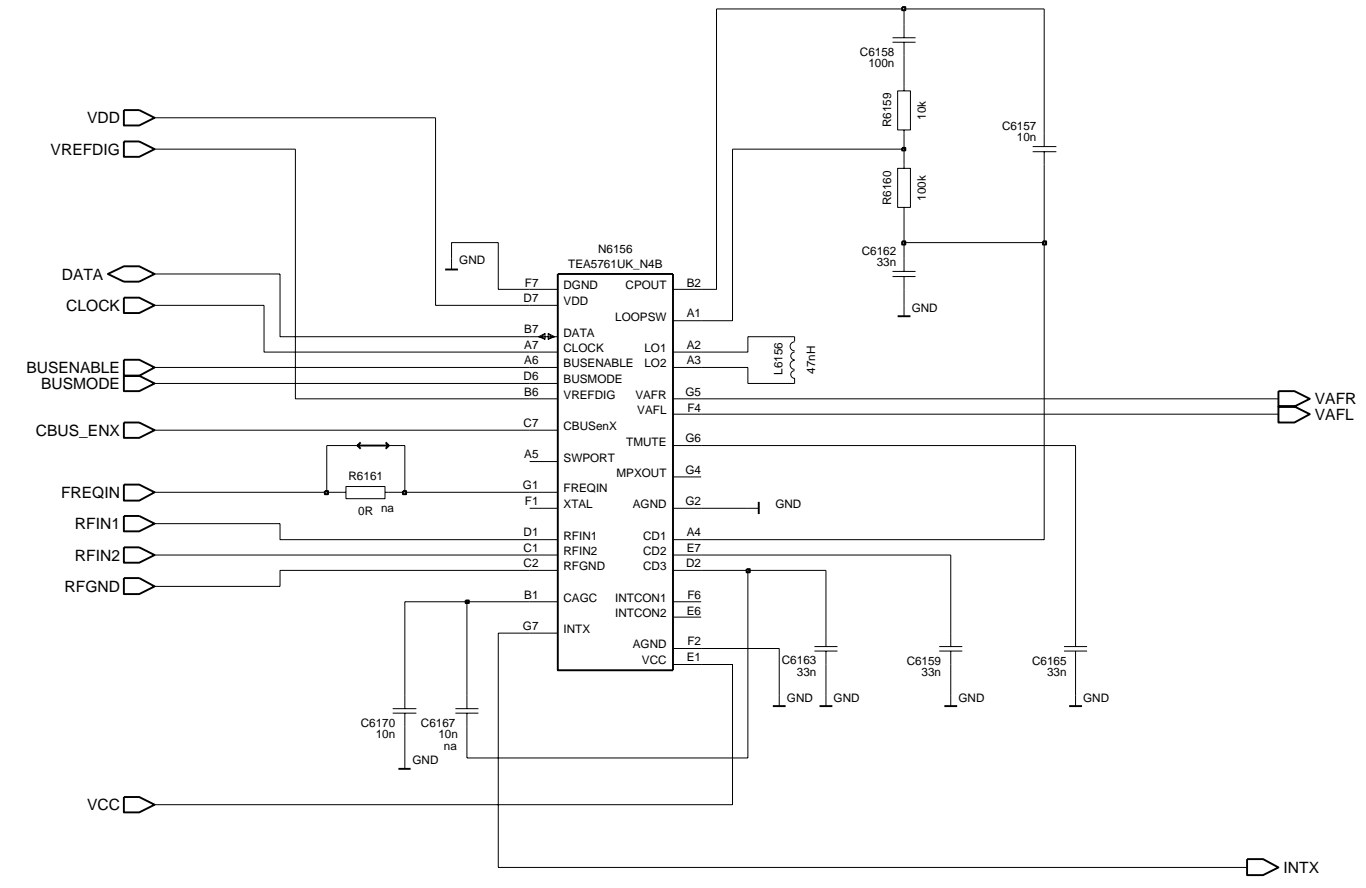

Copyright (C) Nokia Corporation. All rights reserved.  
 THIS DRAWING IS PROTECTED BY COPYRIGHT AS AN UNPUBLISHED WORK.  
 UNAUTHORIZED REPRODUCTION OF THIS DRAWING IS NOT PERMITTED.  
 THIS DRAWING CONTAINS PROPRIETARY AND CONFIDENTIAL INFORMATION.  
 This document is property of Nokia Corporation



Name	TEA5761UK	Appr	dd-mmm-yy
Assoc		Des.	P.J.Waterman 21-May-03
		Dr.	ZIEGER 22-Nov-05
File	\$/COSMO/pro/engine/1fw_20/SYS/cellular/cmt_if/fmradio/fmradio_main_ic	Sheet	11 of 34 2 (01)
Proj	Radiohead	Print	Yes V. 0.0 Edit 41

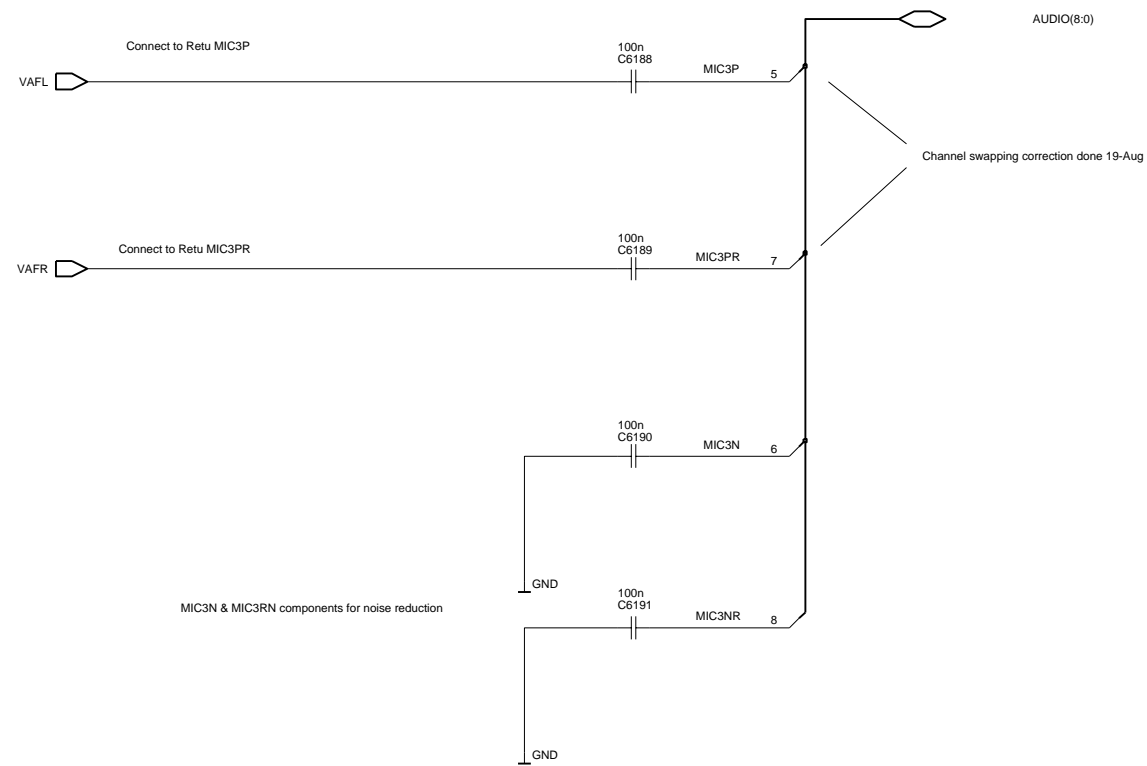

Copyright (C) Nokia Corporation. All rights reserved.  
 THIS DRAWING IS PROTECTED BY COPYRIGHT AS AN UNPUBLISHED WORK.  
 UNAUTHORIZED REPRODUCTION OF THIS DRAWING IS NOT PERMITTED.  
 THIS DRAWING CONTAINS PROPRIETARY AND CONFIDENTIAL INFORMATION.  
 This document is property of Nokia Corporation



Name	Differential Stereo	Appr	dd-mmm-yy
Assoc	DCT45 Common Baseband	Des.	Keith Winfield 02-Feb-2001
		Dr.	ZIEGER 11-Oct-05
File	\$COSMO/pro/engine/1fw_20/SYS/cellular/cmt_if/fmradio/fm_out		Sheet 12 of 34 1 (01)
Proj	DCT45 Common Baseband	Draw.	Print Yes V. 0.0 Edit 35

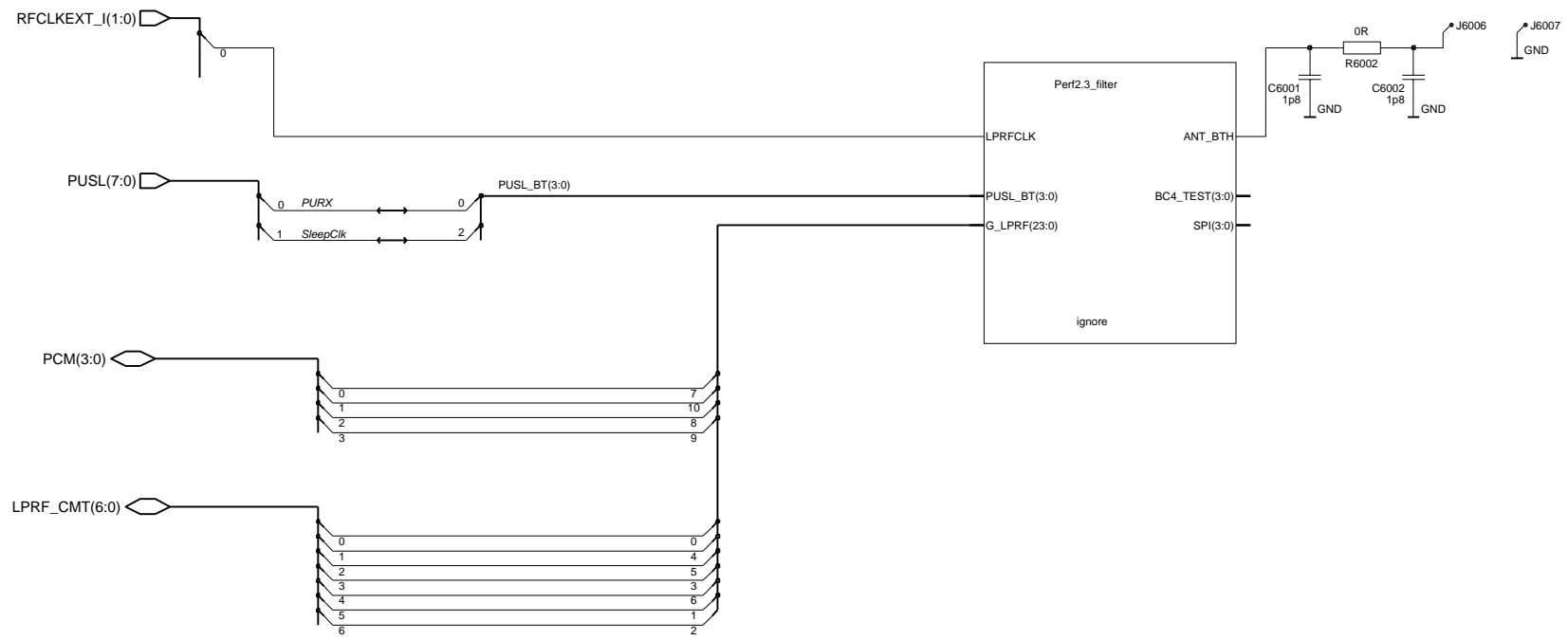

Copyright (C) Nokia Corporation. All rights reserved.  
 THIS DRAWING IS PROTECTED BY COPYRIGHT AS AN UNPUBLISHED WORK.  
 UNAUTHORIZED REPRODUCTION OF THIS DRAWING IS NOT PERMITTED.  
 THIS DRAWING CONTAINS PROPRIETARY AND CONFIDENTIAL INFORMATION.  
 This document is property of Nokia Corporation



Name	BTH	Appr	dd-mmm-yy
Assoc	Cosmo B1.0	Des.	FIELD 25-Sept-03
		Dr.	ZIEGER 10-Feb-06
File	\$COSMO/pro/engine/1fa_30/SYS/cellular/cmt_if/lprf		Sheet 13 of 34 1 (01)
Proj	COSMO	Draw.	Print Yes v. 0 Edit 141

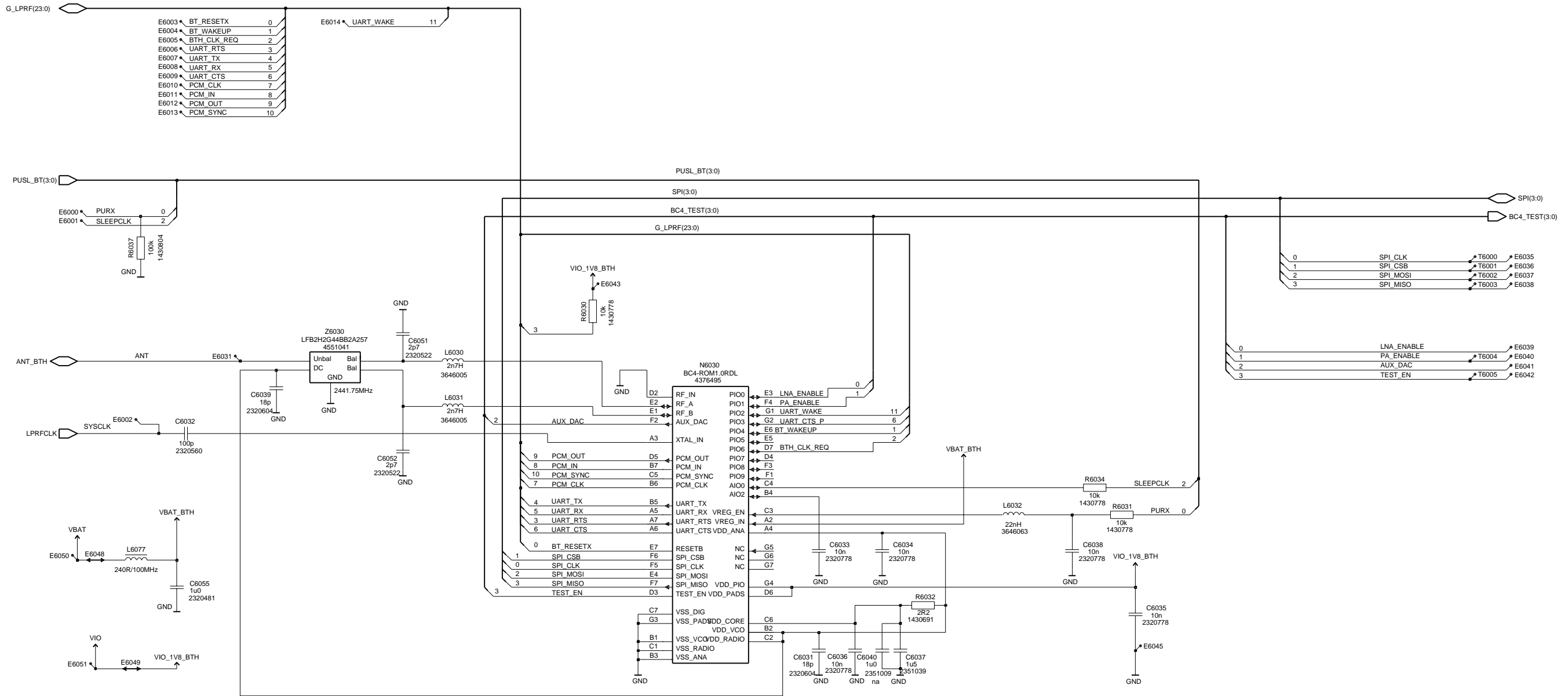

Notes

- (1) UART\_RTS on BC4 (A7) should be used for coms link
- (2) For EDR testing, provide test pads for SPI, PIO1 and RESETX. TEST\_EN can be left NC in phone.
- (3) VREG\_EN (C3) is noise sensitive. L6032, R6031, C6038 are required for filtering

Copyright (C) Nokia Corporation. All rights reserved. THIS DRAWING IS PROTECTED BY COPYRIGHT AS AN UNPUBLISHED WORK. UNAUTHORIZED REPRODUCTION OF THIS DRAWING IS NOT PERMITTED. THIS DRAWING CONTAINS PROPRIETARY AND CONFIDENTIAL INFORMATION. This document is property of Nokia Corporation			Name BTHPERF 2.3 (BC4 ROM1.0) Assoc _____ Ch. FIELD 20-Dec-04 Des. ANSCOMB 20-Dec-04 Dr. DREWS 06-Feb-06 File \$COSMO/pro/engine/1/tfw_30/SYS/cellular/cmt_if/perf2_3_filter Proj BLUEBIRD P1501	Appr _____ Des. ANSCOMB 20-Dec-04 Dr. DREWS 06-Feb-06 Sheet 14 of 34 0 (01) Print Yes V. Edit 14
---	--	---	---	--

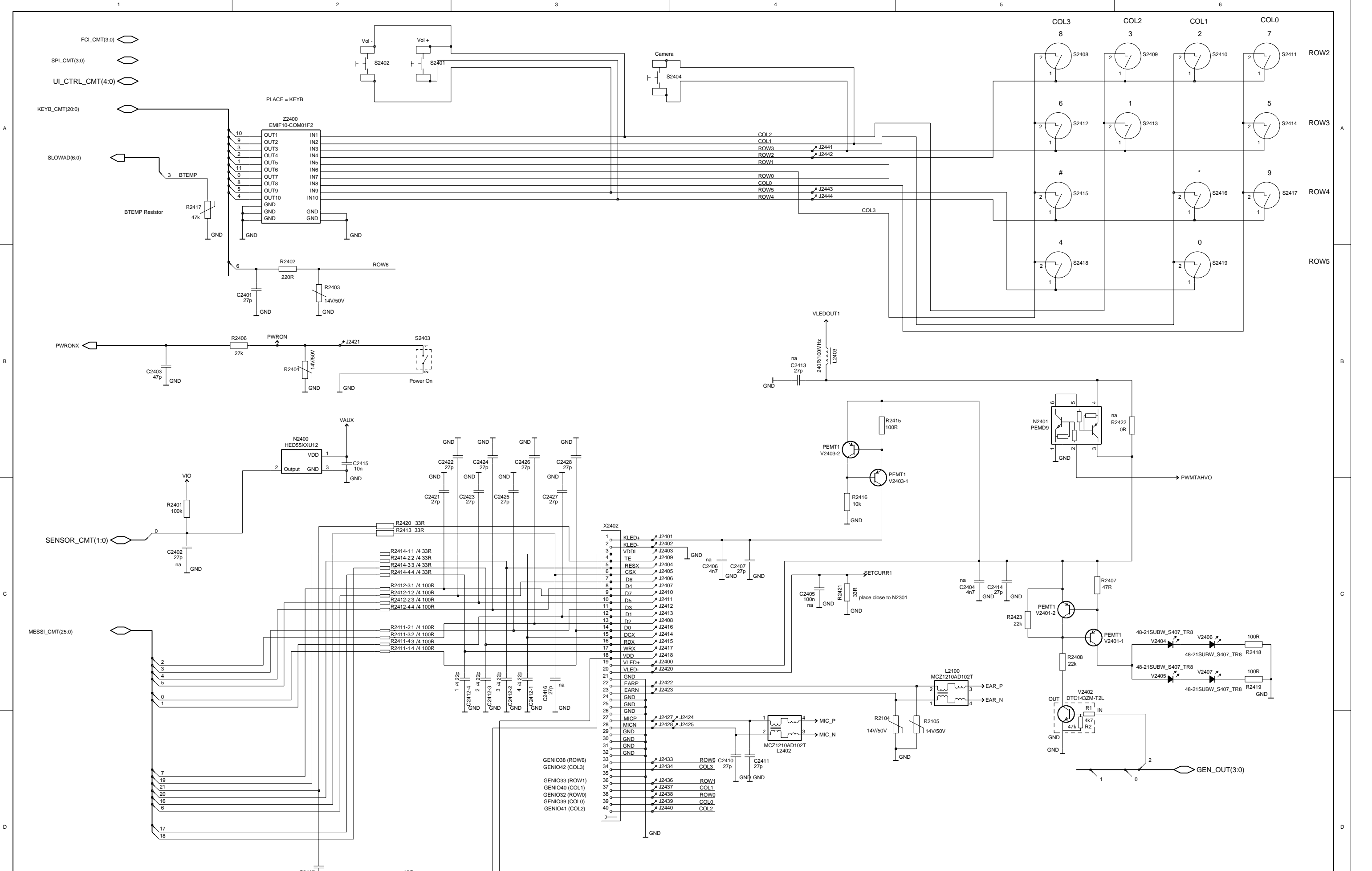

Copyright (C) Nokia Corporation. All rights reserved.  
 THIS DRAWING IS PROTECTED BY COPYRIGHT AS AN UNPUBLISHED WORK.  
 UNAUTHORIZED REPRODUCTION OF THIS DRAWING IS NOT PERMITTED.  
 THIS DRAWING CONTAINS PROPRIETARY AND CONFIDENTIAL INFORMATION.  
 This document is property of Nokia Corporation



Name	UI Interface	Appr	dd-mmm-yy
Assoc	Cosmo B1.0	Des.	11-Jun-03
File	\$COSMO/pro/engine/1fw_30/SYS/cellular/cmt_if/ui	Dr.	DREWS 07-Feb-06
Proj	GRAPE	Sheet	15 of 34
		Print	Yes
		V.	0.0
		Draw.	147

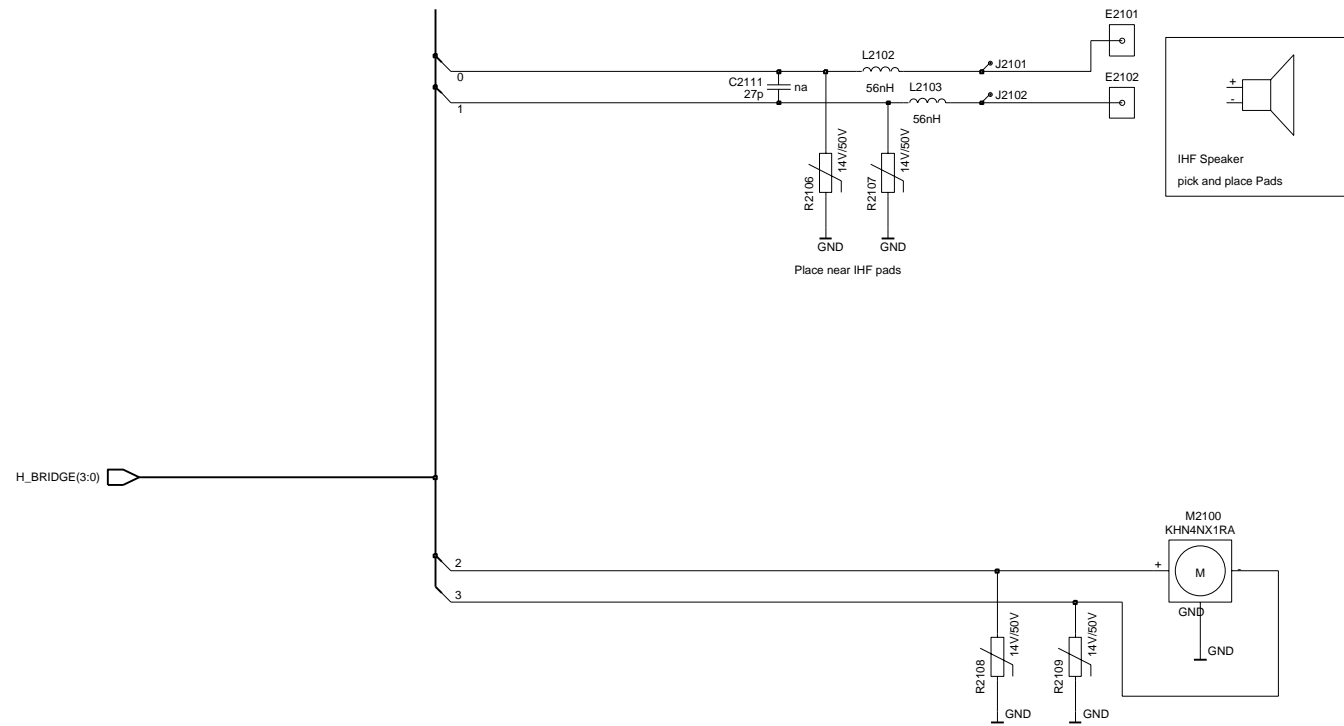
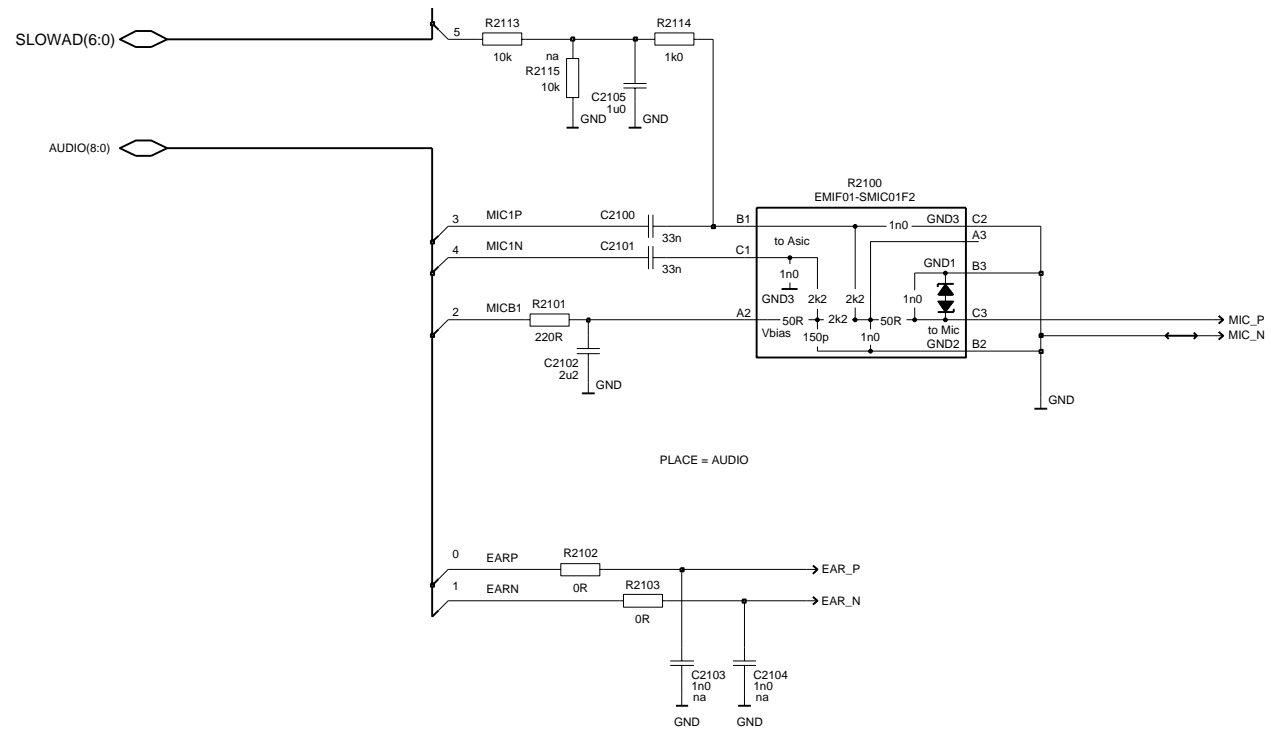

Copyright (C) Nokia Corporation. All rights reserved.  
 THIS DRAWING IS PROTECTED BY COPYRIGHT AS AN UNPUBLISHED WORK.  
 UNAUTHORIZED REPRODUCTION OF THIS DRAWING IS NOT PERMITTED.  
 THIS DRAWING CONTAINS PROPRIETARY AND CONFIDENTIAL INFORMATION.  
 This document is property of Nokia Corporation



Name	Audio	Appr	dd-mmm-yy
Assoc	Cosmo B1.0	Des.	11-Jun-03
File	\$COSMO/pro/engine/1fw_30/SYS/cellular/cmt_if/audio	Dr.	DREWS 06-Feb-06
Proj	GRAPE	Sheet	16 of 34 1 (01)
		Print	Yes V. 0.0 Edit 76



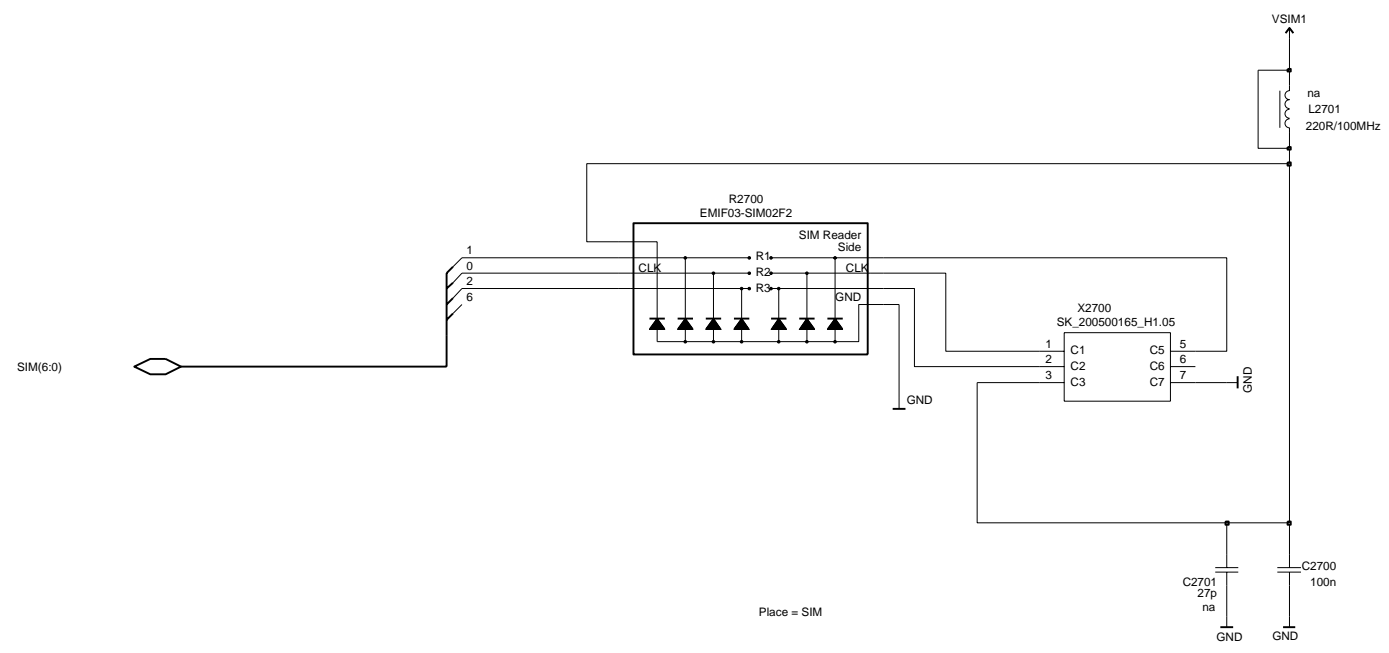

Copyright (C) Nokia Corporation. All rights reserved.  
 THIS DRAWING IS PROTECTED BY COPYRIGHT AS AN UNPUBLISHED WORK.  
 UNAUTHORIZED REPRODUCTION OF THIS DRAWING IS NOT PERMITTED.  
 THIS DRAWING CONTAINS PROPRIETARY AND CONFIDENTIAL INFORMATION.  
 This document is property of Nokia Corporation



Name	SIM interface	Appr	dd-mmm-yy
Assoc	Cosmo B1.0	Des.	11-Jun-03
File	Proj	Dr.	Sheet
\$COSMO/pro/engine/1fw_20/SYS/cellular/cmt_if/sim	GRAPE	ZIEGER	17 of 34
			1 (01)
		Print	Yes
		V.	0.0
		Edit	42

PUSL(7:0)

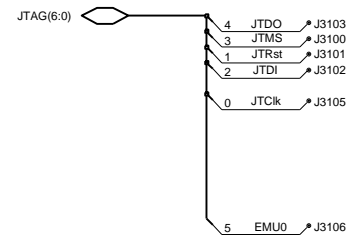

If possible place so that JTAG flex can be soldered to pattern (testpad J3100-3107)

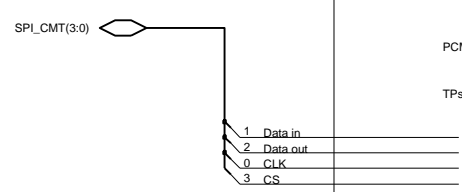
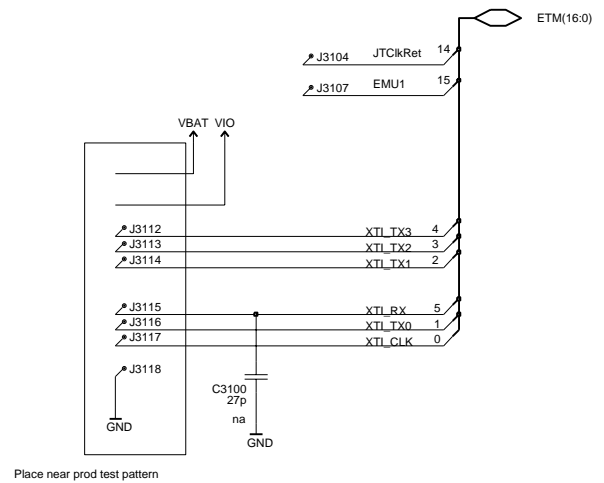

PCM interface to/from Audio Precision  
TPs not needed in SOHO proto board

Copyright (C) Nokia Corporation. All rights reserved. THIS DRAWING IS PROTECTED BY COPYRIGHT AS AN UNPUBLISHED WORK. UNAUTHORIZED REPRODUCTION OF THIS DRAWING IS NOT PERMITTED. THIS DRAWING CONTAINS PROPRIETARY AND CONFIDENTIAL INFORMATION. This document is property of Nokia Corporation				Name Test Interface Assoc Cosmo B1.0 File \$COSMO/pro/engine/1fw_20/SYS/cellular/cmt_if/emu_rap Proj CBB5X		Appr dd-mmm-yy Des. KAYRA 04-Jun-98 Dr. ZIEGER 11-Oct-05 Sheet 18 of 34 1(01) Print Yes V. 1.3 Edit 28	
---	--	--	--	---	--	--	--

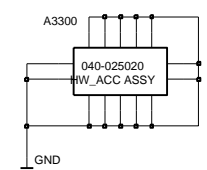
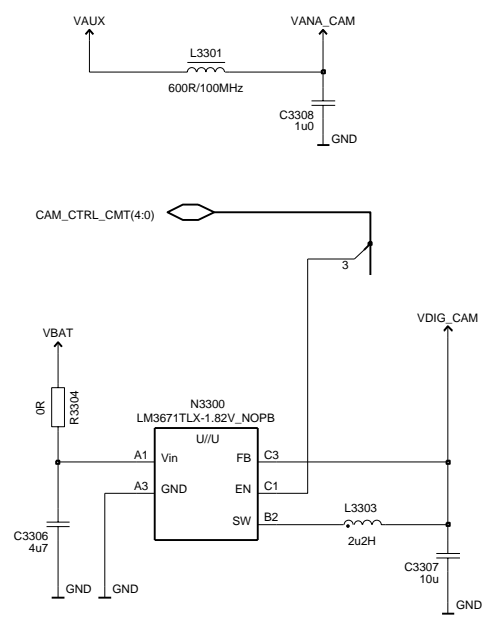
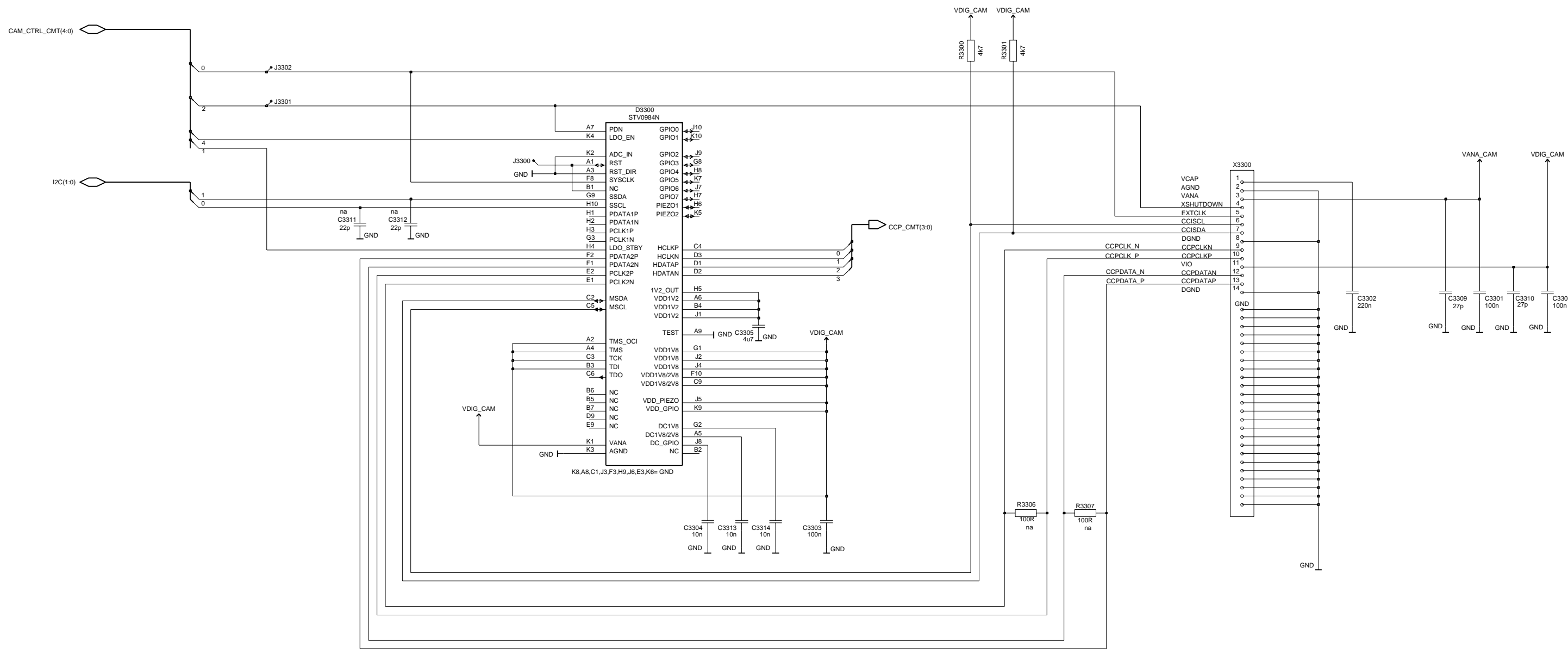

Copyright (C) Nokia Corporation. All rights reserved. THIS DRAWING IS PROTECTED BY COPYRIGHT AS AN UNPUBLISHED WORK. UNAUTHORIZED REPRODUCTION OF THIS DRAWING IS NOT PERMITTED. THIS DRAWING CONTAINS PROPRIETARY AND CONFIDENTIAL INFORMATION. This document is property of Nokia Corporation				Name Camera Interface Assoc Cosmo B1.0 File \$COSMO/pro/engine/1fw_30/SYS/cellular/cmt_if/camera Proj SOHO		Appr dd-mmm-yy Des. 11-Jun-03 Dr. DREWS 17-Jan-06 Sheet 19 of 34 Print Yes V. 0.0 Edit 106	
---	--	--	--	---	--	--	--

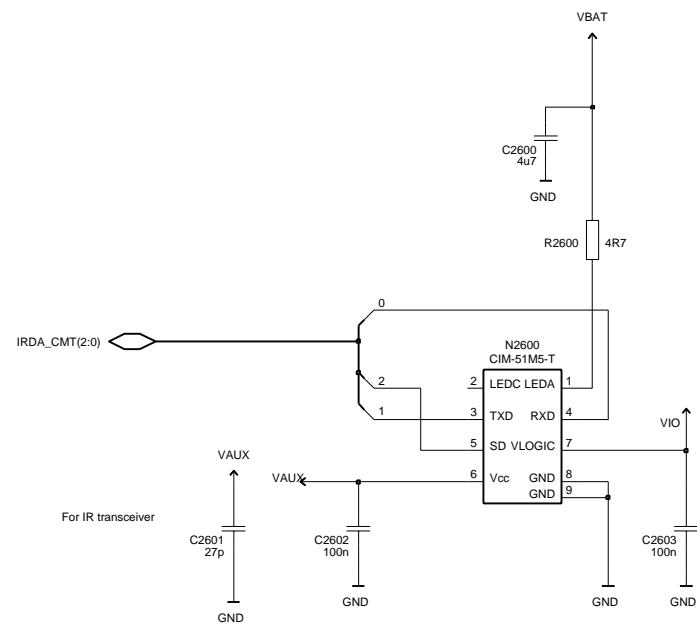

Copyright (C) Nokia Corporation. All rights reserved.  
 THIS DRAWING IS PROTECTED BY COPYRIGHT AS AN UNPUBLISHED WORK.  
 UNAUTHORIZED REPRODUCTION OF THIS DRAWING IS NOT PERMITTED.  
 THIS DRAWING CONTAINS PROPRIETARY AND CONFIDENTIAL INFORMATION.  
 This document is property of Nokia Corporation



Name	IrDa Interface	Appr	dd-mmm-yy
Assoc	Lloyd B1.0	Des.	11-Jun-03
File	\$(COSMO/pro/engine/1fw_30/SYS/cellular/cmt_if/irda	Dr.	DREWS
Proj	LLOYD	Sheet	20 of 34
		Print	Yes
		V.	0.2
		Edit	53

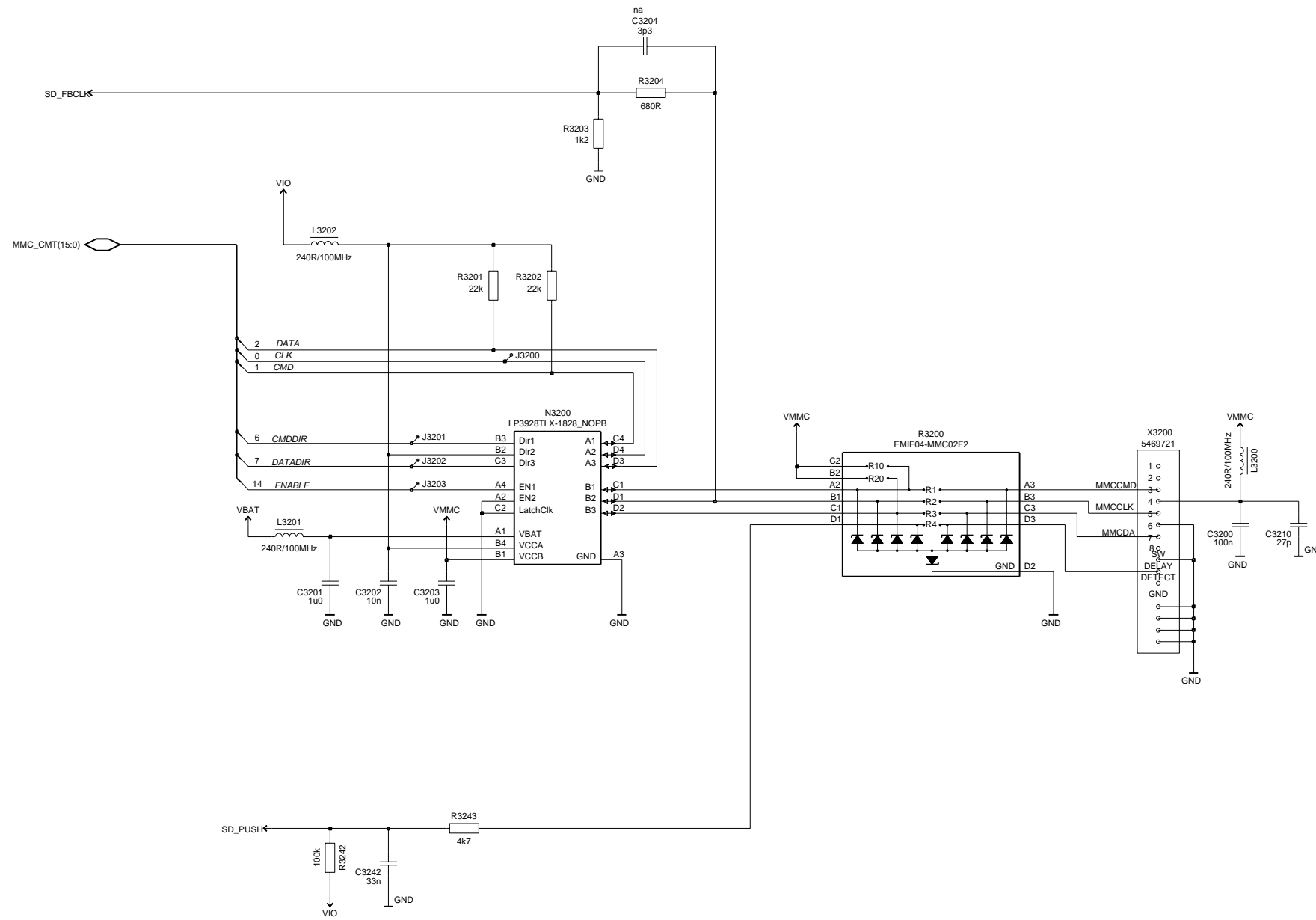

Copyright (C) Nokia Corporation. All rights reserved.  
 THIS DRAWING IS PROTECTED BY COPYRIGHT AS AN UNPUBLISHED WORK.  
 UNAUTHORIZED REPRODUCTION OF THIS DRAWING IS NOT PERMITTED.  
 THIS DRAWING CONTAINS PROPRIETARY AND CONFIDENTIAL INFORMATION.  
 This document is property of Nokia Corporation



Name	Top part - SD-Card interface	Appr	16-Jun-04
Assoc	Cosmo	Des.	SRLARSEN 13-Sep-04
		Dr.	DREWS 06-Feb-06
File	\$COSMO/pro/engine/1fw_30/SYS/cellular/cmt_if/mmc		Sheet 21 of 34 1 (01)
Proj	Cosmo	Draw.	Print YES V. 1.0 Edit 34

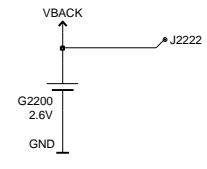
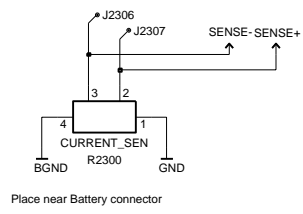
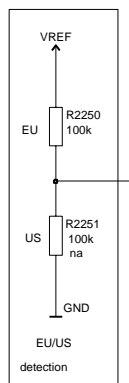
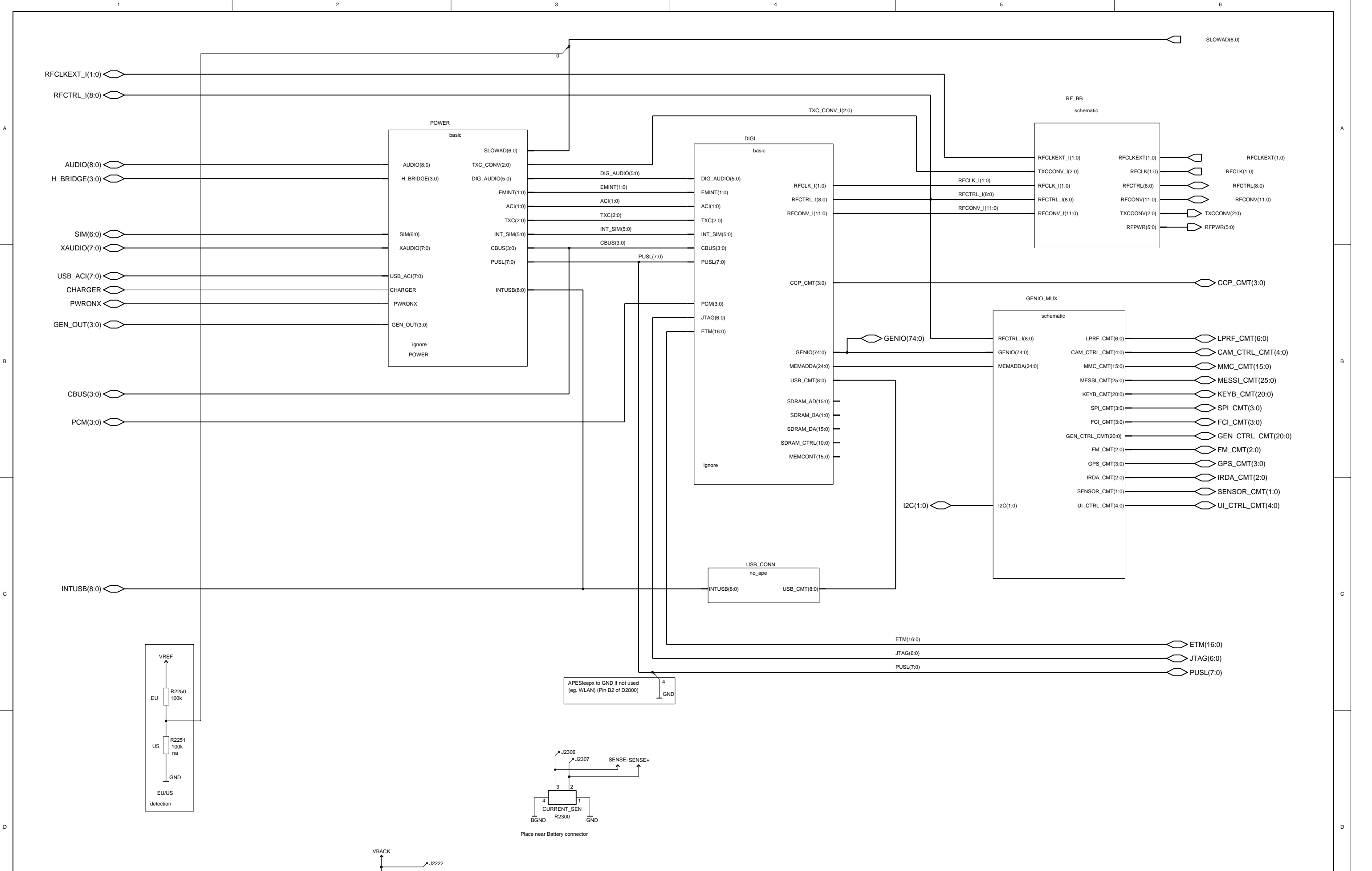

Copyright (C) Nokia Corporation. All rights reserved.  
 THIS DRAWING IS PROTECTED BY COPYRIGHT AS AN UNPUBLISHED WORK.  
 UNAUTHORIZED REPRODUCTION OF THIS DRAWING IS NOT PERMITTED.  
 THIS DRAWING CONTAINS PROPRIETARY AND CONFIDENTIAL INFORMATION.  
 This document is property of Nokia Corporation



Name	CMT_Engine Top level	Appr	dd-mmm-yy
Assoc	Cosmo B1.0	Des.	ArKa 27-May-03
File	\$/COSMO/pro/engine/1fw_20/SYS/cellular/cmt_engine	Dr.	ZIEGER 11-Oct-05
Proj	GRAPE	Sheet	22 of 34 3 (01)
		Print	Yes V. 0.0 Edit 175

Placement reservation for ESD imprment

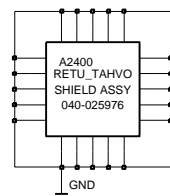
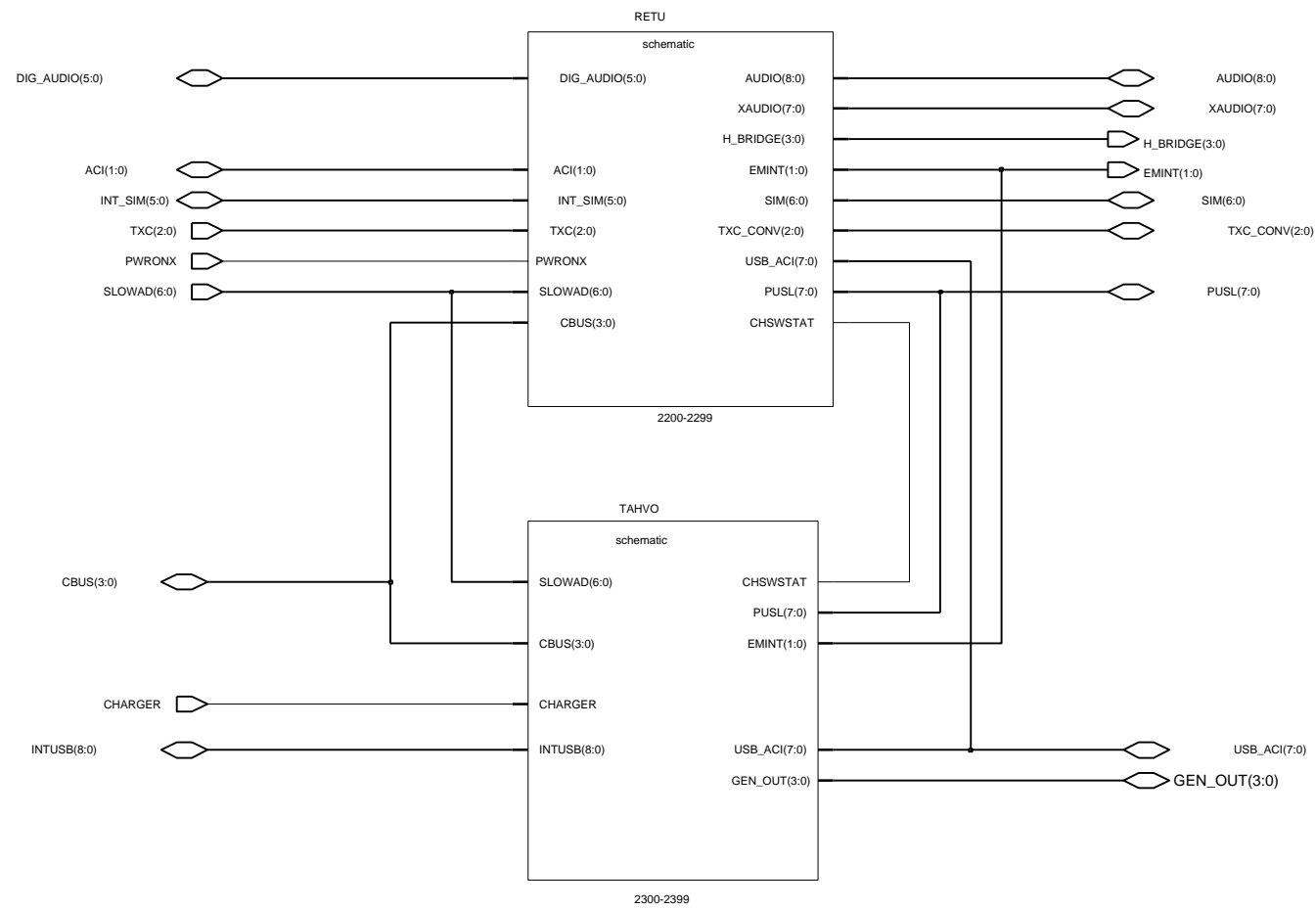

Copyright (C) Nokia Corporation. All rights reserved.  
 THIS DRAWING IS PROTECTED BY COPYRIGHT AS AN UNPUBLISHED WORK.  
 UNAUTHORIZED REPRODUCTION OF THIS DRAWING IS NOT PERMITTED.  
 THIS DRAWING CONTAINS PROPRIETARY AND CONFIDENTIAL INFORMATION.  
 This document is property of Nokia Corporation



Name	Energy management	Appr	dd-mmm-yy
Assoc		Des.	KAYRA 15-Jan-03
		Dr.	ZIEGER 15-Dec-05
File	\$COSMO/pro/engine/1fw_30/SYS/cellular/cmt_engine/power_22jun05		Sheet 25 of 34 1 (01)
Proj	Cement G3.1S	Draw.	Print Yes v. 0 Edit 44

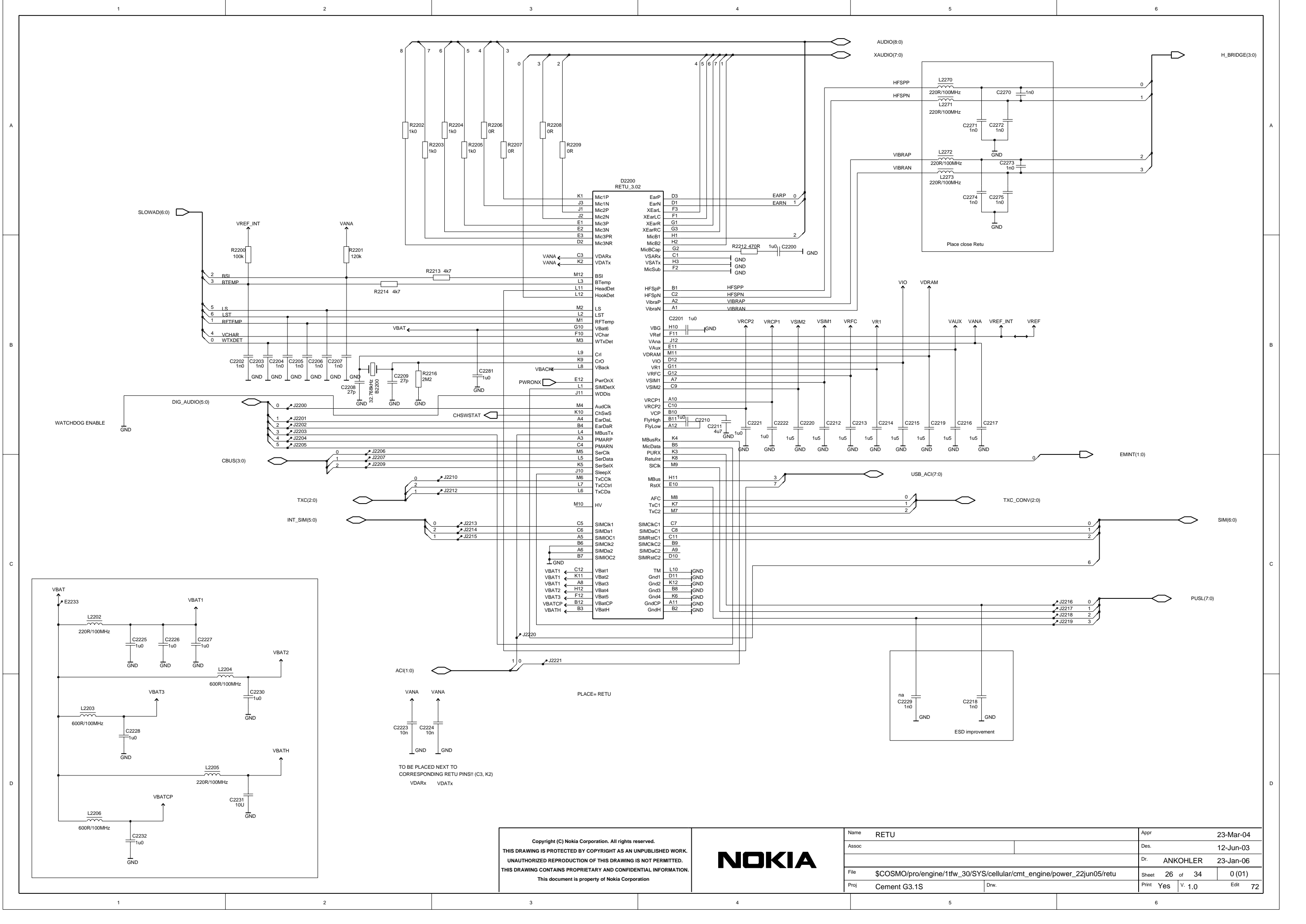

Copyright (C) Nokia Corporation. All rights reserved.  
 THIS DRAWING IS PROTECTED BY COPYRIGHT AS AN UNPUBLISHED WORK.  
 UNAUTHORIZED REPRODUCTION OF THIS DRAWING IS NOT PERMITTED.  
 THIS DRAWING CONTAINS PROPRIETARY AND CONFIDENTIAL INFORMATION.  
 This document is property of Nokia Corporation



Name	RETU	Appr	23-Mar-04
Assoc		Des.	12-Jun-03
File	\$COSMO/pro/engine/1fw_30/SYS/cellular/cmt_engine/power_22jun05/retu	Dr.	ANKOHLER 23-Jan-06
Proj	Cement G3.1S	Sheet	26 of 34
		Print	Yes
		V.	1.0
		Edit	72



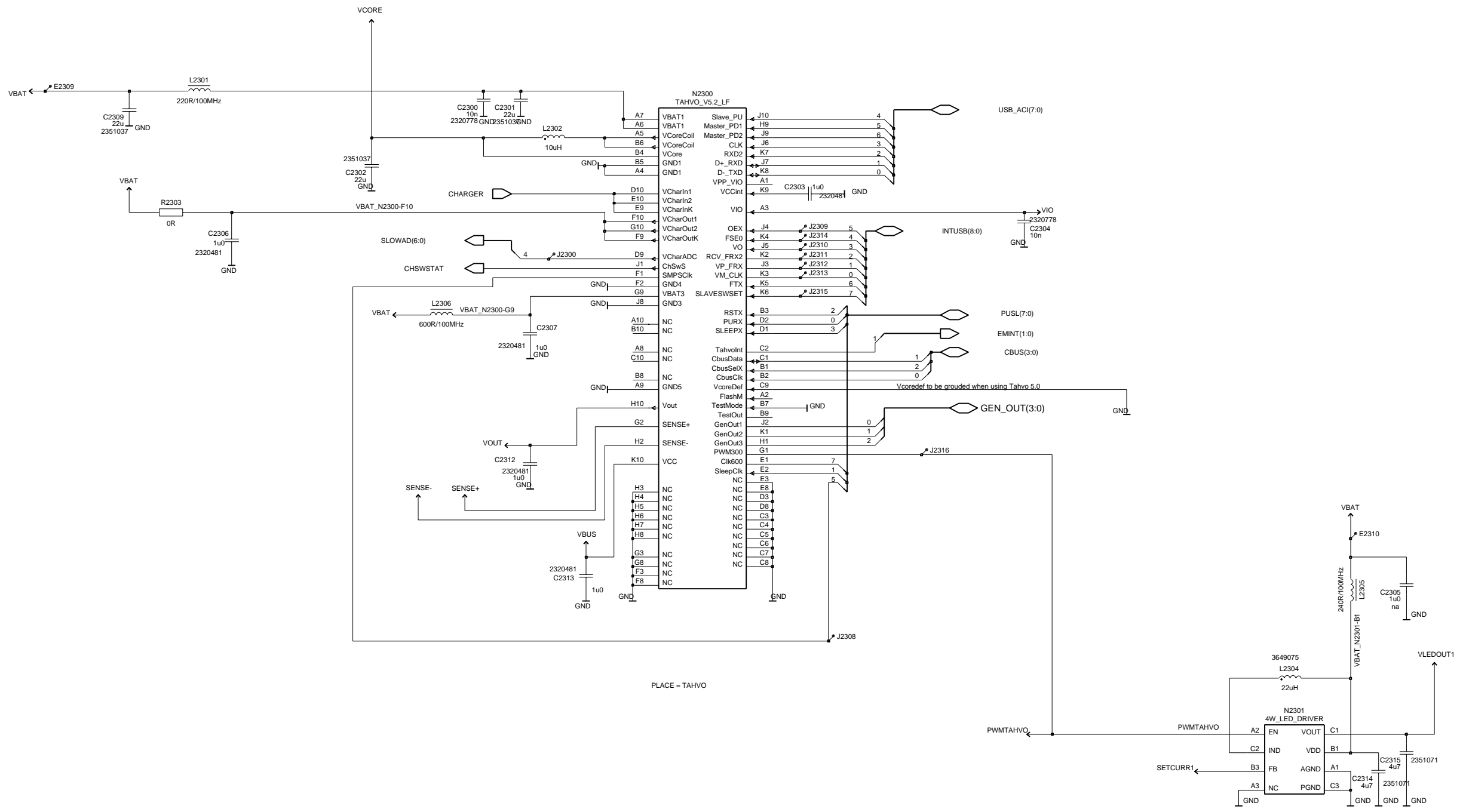

PLACE = TAHVO

Copyright (C) Nokia Corporation. All rights reserved. THIS DRAWING IS PROTECTED BY COPYRIGHT AS AN UNPUBLISHED WORK. UNAUTHORIZED REPRODUCTION OF THIS DRAWING IS NOT PERMITTED. THIS DRAWING CONTAINS PROPRIETARY AND CONFIDENTIAL INFORMATION. This document is property of Nokia Corporation		<b>NOKIA</b>	Name	TAHVO	Appr	23-Mar-04
			Assoc		Des.	12-Jun-03
		File	\$COSMO/pro/engine/1fw_30/SYS/cellular/cmt_engine/power_22jun05/tahvo		Dr.	DREWS 31-Jan-06
		Proj	Cement G3.1S	Draw.	Sheet	27 of 34 0 (01)
				Print	Yes	V. 1.0 Edit 85

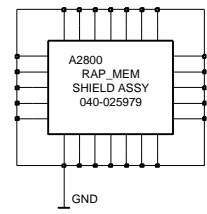
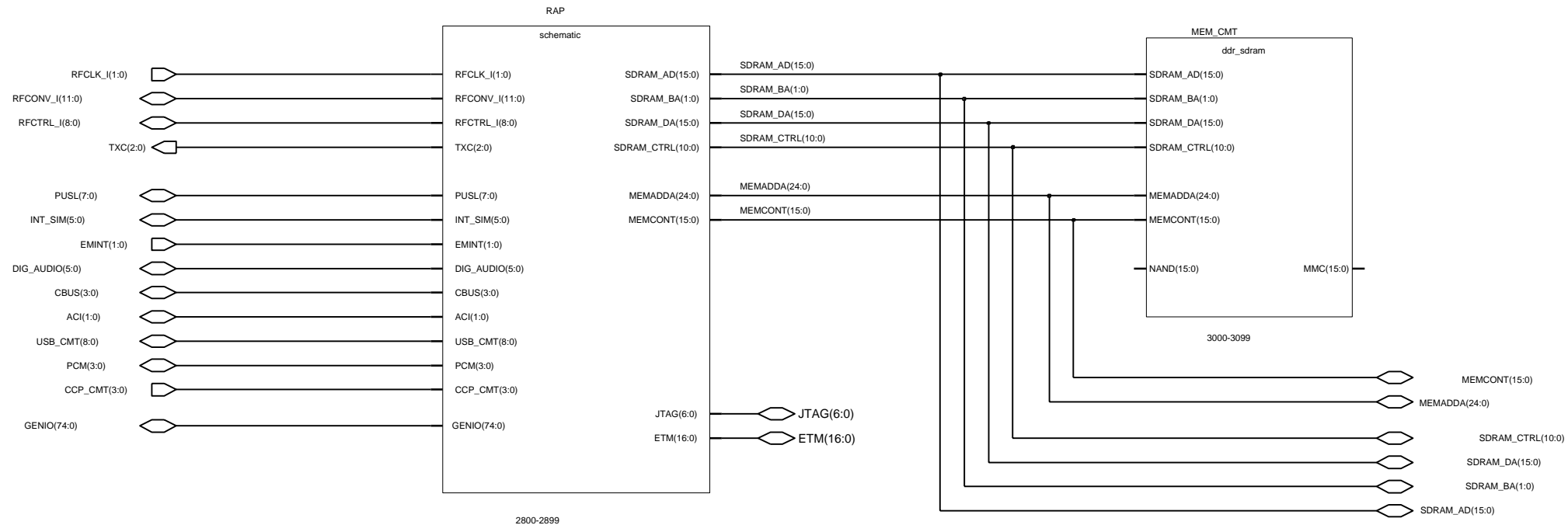

Copyright (C) Nokia Corporation. All rights reserved.  
THIS DRAWING IS PROTECTED BY COPYRIGHT AS AN UNPUBLISHED WORK.  
UNAUTHORIZED REPRODUCTION OF THIS DRAWING IS NOT PERMITTED.  
THIS DRAWING CONTAINS PROPRIETARY AND CONFIDENTIAL INFORMATION.  
This document is property of Nokia Corporation



Name	CMT SUBSYSTEM	Appr	dd-mmm-yy
Assoc		Des.	KAYRA 10-Jan-03
File	Proj	Dr.	DREWS 23-Dec-05
Proj	Cement G3.1S	Sheet	28 of 34 0 (01)
Draw.		Print	Yes v. 0 Edit 37

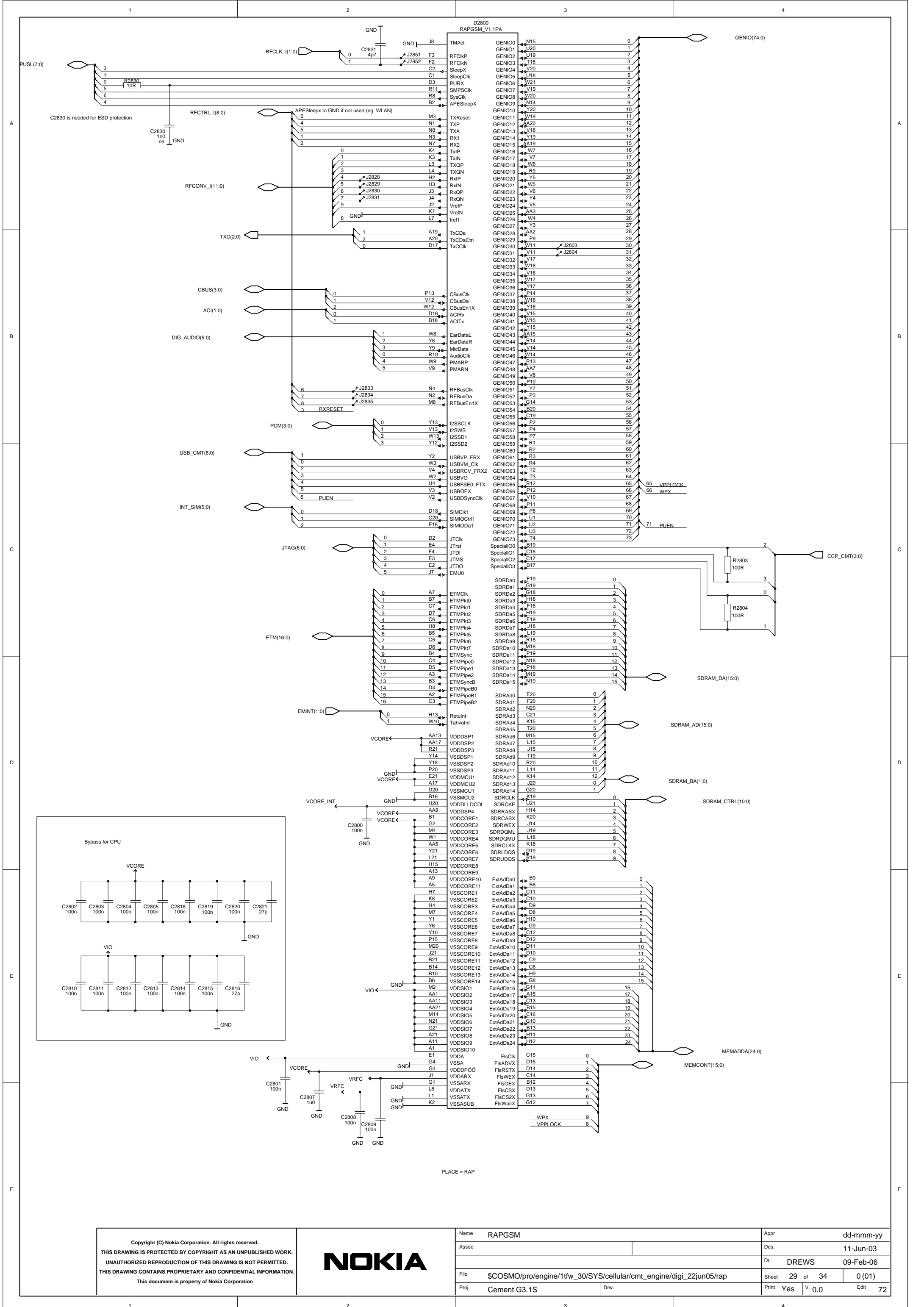

Copyright (C) Nokia Corporation. All rights reserved.  
 THIS DRAWING IS PROTECTED BY COPYRIGHT AS AN UNPUBLISHED WORK.  
 UNAUTHORIZED REPRODUCTION OF THIS DRAWING IS NOT PERMITTED.  
 THIS DRAWING CONTAINS PROPRIETARY AND CONFIDENTIAL INFORMATION.  
 This document is property of Nokia Corporation



Name	RAPGSM	Appr	dd-mmm-yy
Assoc		Des.	11-Jun-03
File	\$COSMO/pro/engine/1tfw_30/SYS/cellular/cmt_engine/digi_22jun05/rap	Dr.	DREWS 09-Feb-06
Proj	Cement G3.1S	Sheet	29 of 34 0 (01)
Draw.		Print	Yes v. 0.0 Edit 72

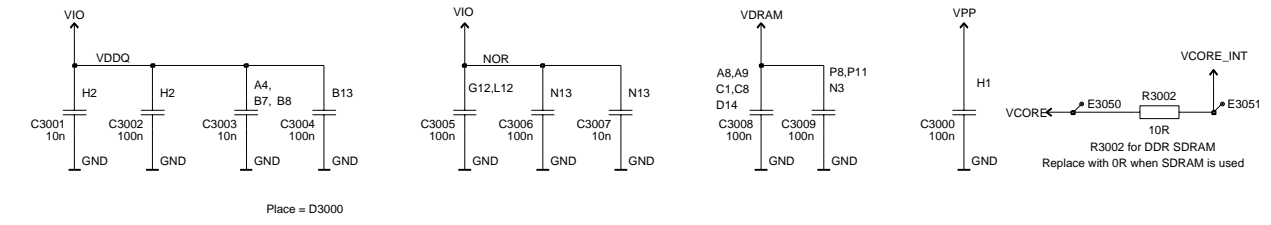
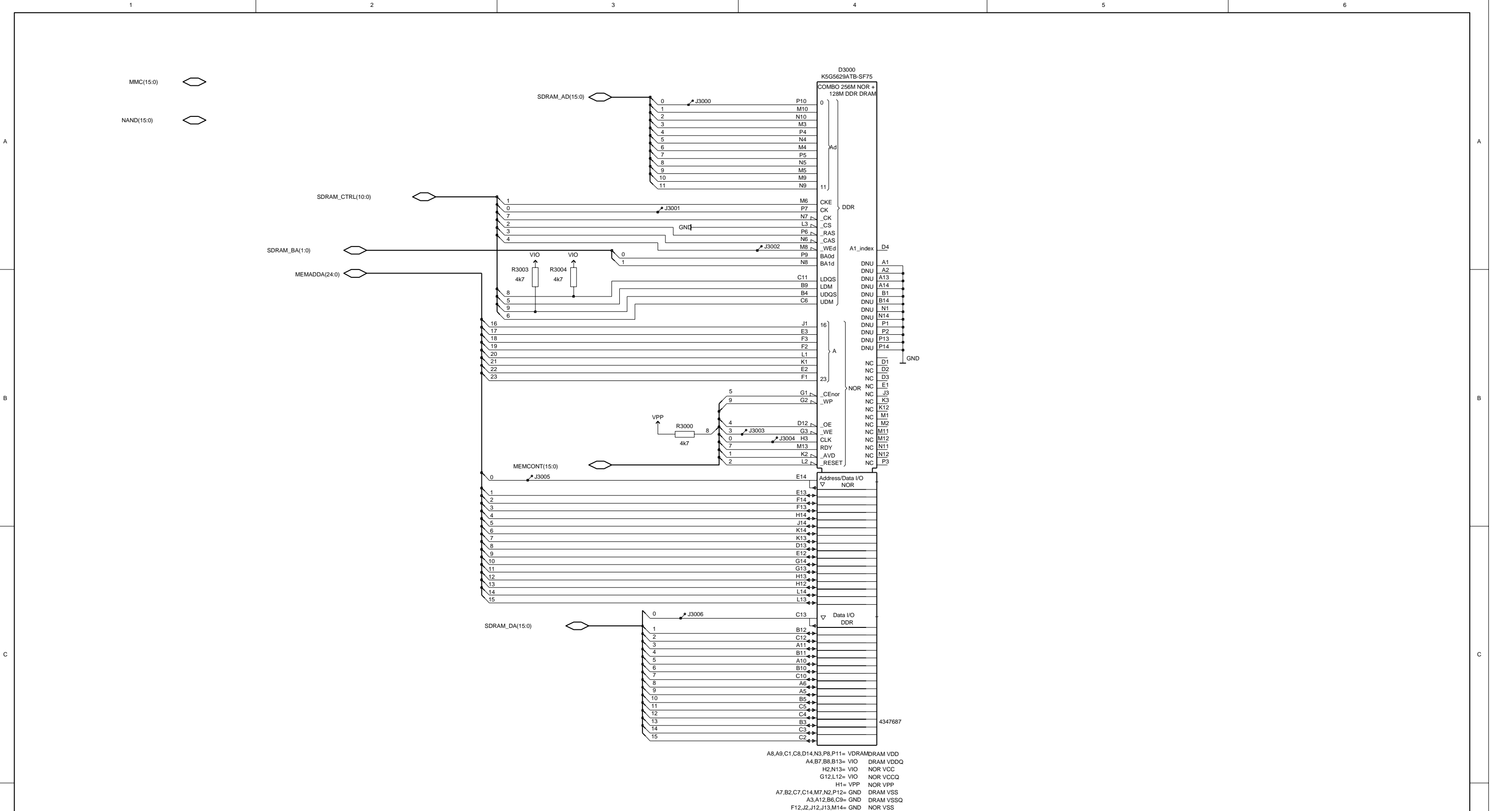

Copyright (C) Nokia Corporation. All rights reserved. THIS DRAWING IS PROTECTED BY COPYRIGHT AS AN UNPUBLISHED WORK. UNAUTHORIZED REPRODUCTION OF THIS DRAWING IS NOT PERMITTED. THIS DRAWING CONTAINS PROPRIETARY AND CONFIDENTIAL INFORMATION. This document is property of Nokia Corporation				Name	CMT Memories		Appr	dd-mmm-yy	
				Assoc	256Mbit NOR + 128 DDR SDRAM Combo Memory		Des.	11-Jun-03	
		File	\$/COSMO/pro/engine/1fa_30/SYS/cellular/cmt_engine/digi_22jun05/mem_cmt		Dr.	ZIEGER		10-Feb-06	
		Proj	Cement G3.1S		Sheet	30 of 34	0 (01)		
		Print	Yes	V. 0.0	Edit	79			

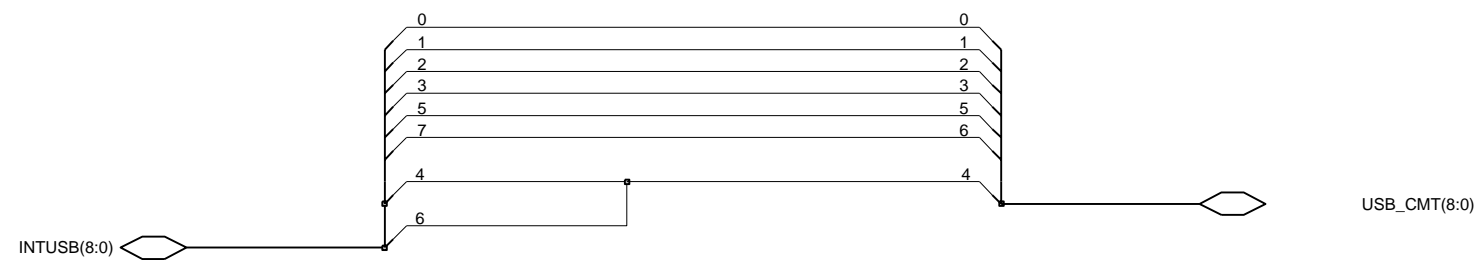

Copyright (C) Nokia Corporation. All rights reserved.  
 THIS DRAWING IS PROTECTED BY COPYRIGHT AS AN UNPUBLISHED WORK.  
 UNAUTHORIZED REPRODUCTION OF THIS DRAWING IS NOT PERMITTED.  
 THIS DRAWING CONTAINS PROPRIETARY AND CONFIDENTIAL INFORMATION.  
 This document is property of Nokia Corporation



Name	USB Connections without APE	Appr	dd-mmm-yy
Assoc	Yoda S0.5	Des.	KatjaKnu 04-Jun-03
		Dr.	ZIEGER 11-Oct-05
File	\$COSMO/pro/engine/1tfw_20/SYS/cellular/cmt_engine/usb_conn	Sheet	31 of 34 1 (01)
Proj	GRAPE	Print	Yes V. 0.0 Edit 19

CBB5X

TOP SHEET

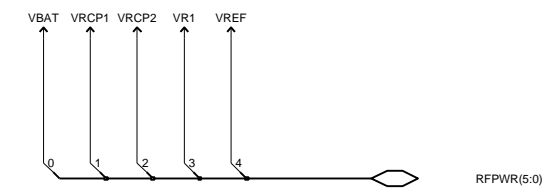
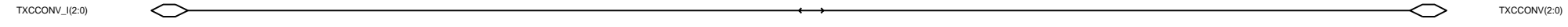
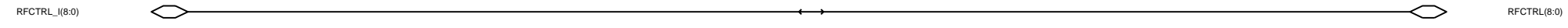
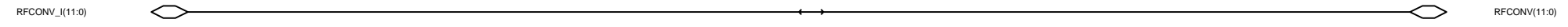
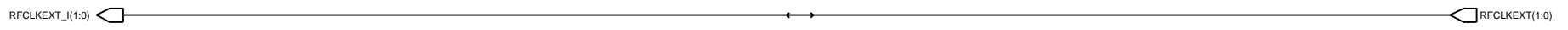
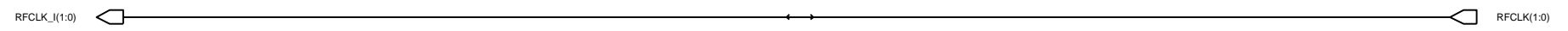

Copyright (C) Nokia Corporation. All rights reserved.  
 THIS DRAWING IS PROTECTED BY COPYRIGHT AS AN UNPUBLISHED WORK.  
 UNAUTHORIZED REPRODUCTION OF THIS DRAWING IS NOT PERMITTED.  
 THIS DRAWING CONTAINS PROPRIETARY AND CONFIDENTIAL INFORMATION.  
 This document is property of Nokia Corporation



Name	RF IF	Appr	dd-mmm-yy
Assoc	Yoda S0.5	Des.	15-Jan-03
File	\$COSMO/pro/engine/1fw_20/SYS/cellular/cmt_engine/rf_bb		Dr. ZIEGER 11-Oct-05
Proj	GRAPE	Sheet 32 of 34	1 (01)
		Print Yes v. 0	Edit 20

From RAPGSM

To CMT\_IF

GENIO(74:0)

UI\_CTRL\_CMT(4:0)

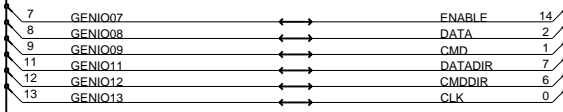

MMC\_CMT(15:0)

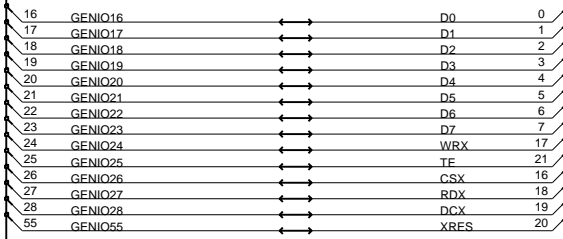

MESSI\_CMT(25:0)

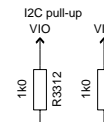

I2C(1:0)

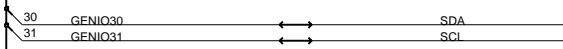

KEYB\_CMT(20:0)

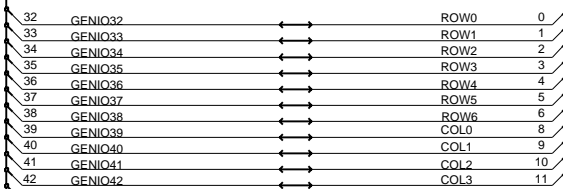

CAM\_CTRL\_CMT(4:0)

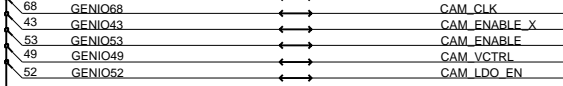

SENSOR\_CMT(1:0)

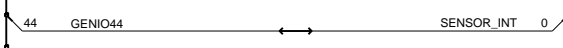

FM\_CMT(2:0)

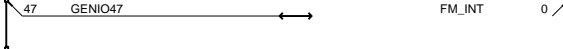

FCI\_CMT(3:0)

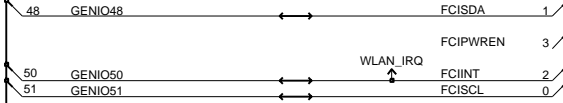

GPS\_CMT(3:0)

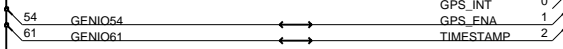

IRDA\_CMT(2:0)

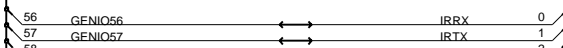

LPRF\_CMT(6:0)

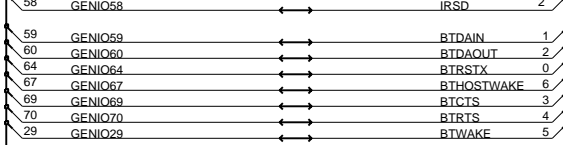

SPI\_CMT(3:0)

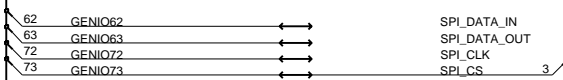

GEN\_CTRL\_CMT(20:0)



MEMADDA(24:0)

RFCTRL\_I(8:0)

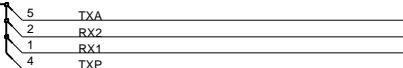

THESE ARE USED BY ENGINE

GENIO65 = VPPLOCK  
GENIO66 = WPX  
GENIO71 = PUEN

DO NOT CHANGE

Copyright (C) Nokia Corporation. All rights reserved.  
 THIS DRAWING IS PROTECTED BY COPYRIGHT AS AN UNPUBLISHED WORK.  
 UNAUTHORIZED REPRODUCTION OF THIS DRAWING IS NOT PERMITTED.  
 THIS DRAWING CONTAINS PROPRIETARY AND CONFIDENTIAL INFORMATION.  
 This document is property of Nokia Corporation



Name	GENIO multiplexing	Appr	dd-mmm-yy
Assoc	Cement G3.1S EB0.50	Des.	G 11-Nov-04
		Dr.	ZIEGER 21-Nov-05
File	\$COSMO/pro/engine/1tfw_20/SYS/cellular/cmt_engine/genio_mux	Sheet	33 of 34 0(01)
Proj	Cement G3.1S	Print	Yes v. 0.0 Edit 43

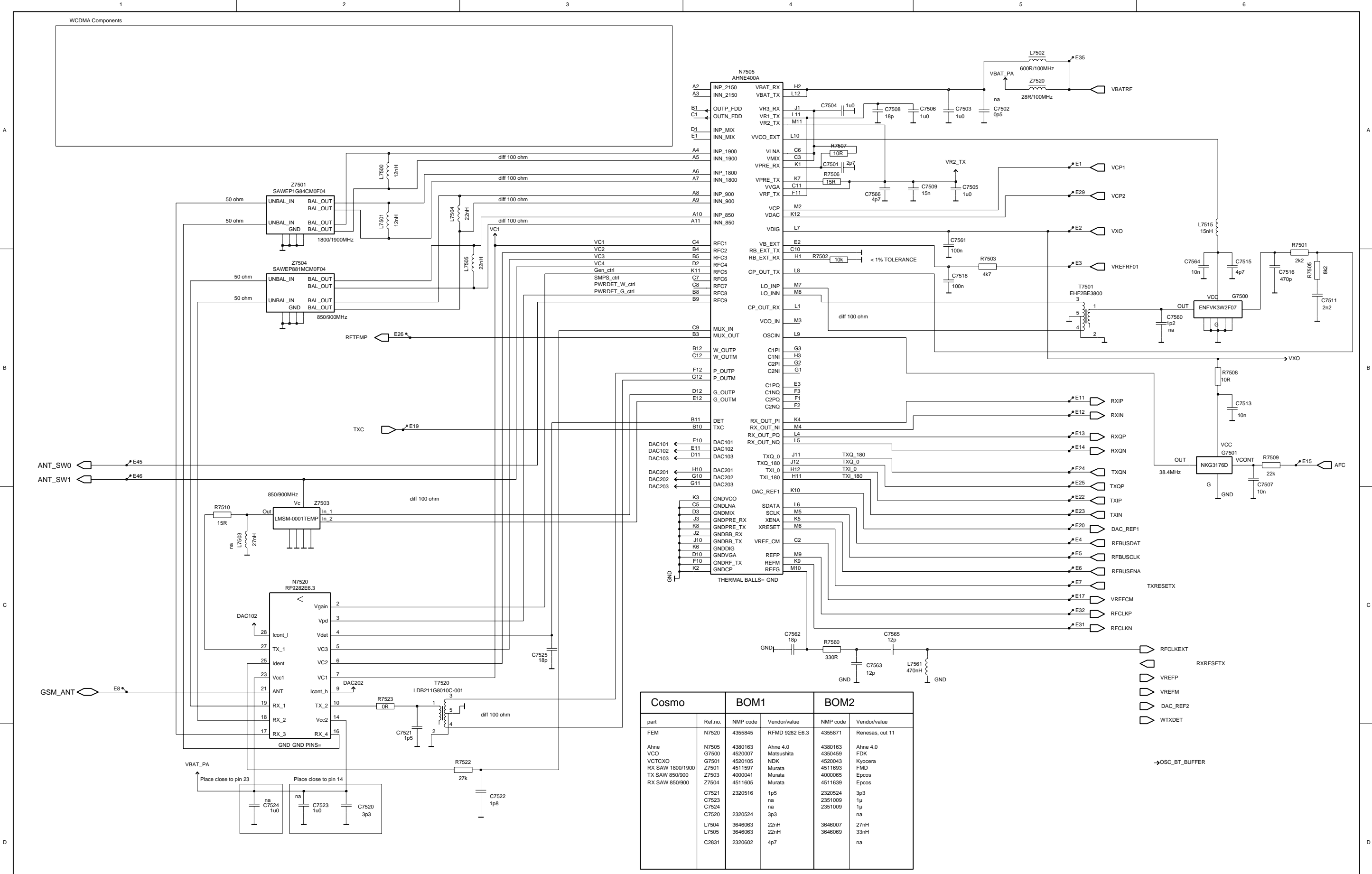

Cosmo		BOM1		BOM2	
part	Ref.no.	NMP code	Vendor/value	NMP code	Vendor/value
FEM	N7520	4355845	RFMD 9282 E6.3	4355871	Renesas, cut 11
Ahne	N7505	4380163	Ahne 4.0	4380163	Ahne 4.0
VCO	G7500	4520007	Matsushita	4350459	FDK
VCTCXO	G7501	4520105	NDK	4520043	Kyocera
RX SAW 1800/900	Z7501	4511597	Murata	4511693	FMD
TX SAW 850/900	Z7503	4000041	Murata	4000065	Epcos
RX SAW 850/900	Z7504	4511605	Murata	4511639	Epcos
	C7521	2320516	1p5	2320524	3p3
	C7523	na	na	2351009	1u
	C7524	na	na	2351009	1u
	C7520	2320524	3p3	na	na
	L7504	3646063	22nH	3646007	27nH
	L7505	3646063	22nH	3646069	33nH
	C2831	2320602	4p7	na	na

Copyright (C) Nokia Corporation. All rights reserved.  
 THIS DRAWING IS PROTECTED BY COPYRIGHT AS AN UNPUBLISHED WORK.  
 UNAUTHORIZED REPRODUCTION OF THIS DRAWING IS NOT PERMITTED.  
 THIS DRAWING CONTAINS PROPRIETARY AND CONFIDENTIAL INFORMATION.  
 This document is property of Nokia Corporation



Name	RF REUSE BLOCK SCHEMATIC, including WCDMA RX & TX Filters		Appr	KMalmivirta	dd-mmm-yy
Assoc	rf1m_06 & rf1m_07		Des.	sgu/JLarsen	21-Jul-04
			Dr.	DREWS	09-Feb-06
File	SCOSMO/pro/engine/1tfw_30/rf1m_11		Sheet	34 of 34	0 (01)
Prj	CUCKOO	Drw.	Print	Yes	V. 10
			Edit		56